



RME MADI Router

How to distribute and route MADI streams between several different audio „worlds“?

Client

Rent-All is a versatile rental company in Europe for light, sound, video and rigging. Rent-All provides a wide range of equipment from stock for use in theater, television, concerts and exhibitions.

RME MADI Router

The MADI Router is a compact device designed to link MADI devices of any manufacturer with unprecedented flexibility in signal routing. It provides this flexibility by serving as a format converter between optical and electrical signals, as a signal repeater, and as a distributor and merger of several MADI signals, all at the same time.

The MADI Router combines many advantages of point-to-point audio connections, such as low latency and fast recovery time from signal line interruptions, with the flexibility of networked audio connections in which any device has access to any channel available on the network of connected devices.

► Project / Client

Rent-All BV
Eurovision Song Contest 2014

► Target

Distribute and route MADI streams between different locations of the production.

► Solution

Usage of 5 RME MADI Routers to connect Backtrack, Monitor World, FOH and OB Compound in a simple and stable way.

► Benefits

Unlimited possibilities in routing complete MADI streams or mono audio channels.

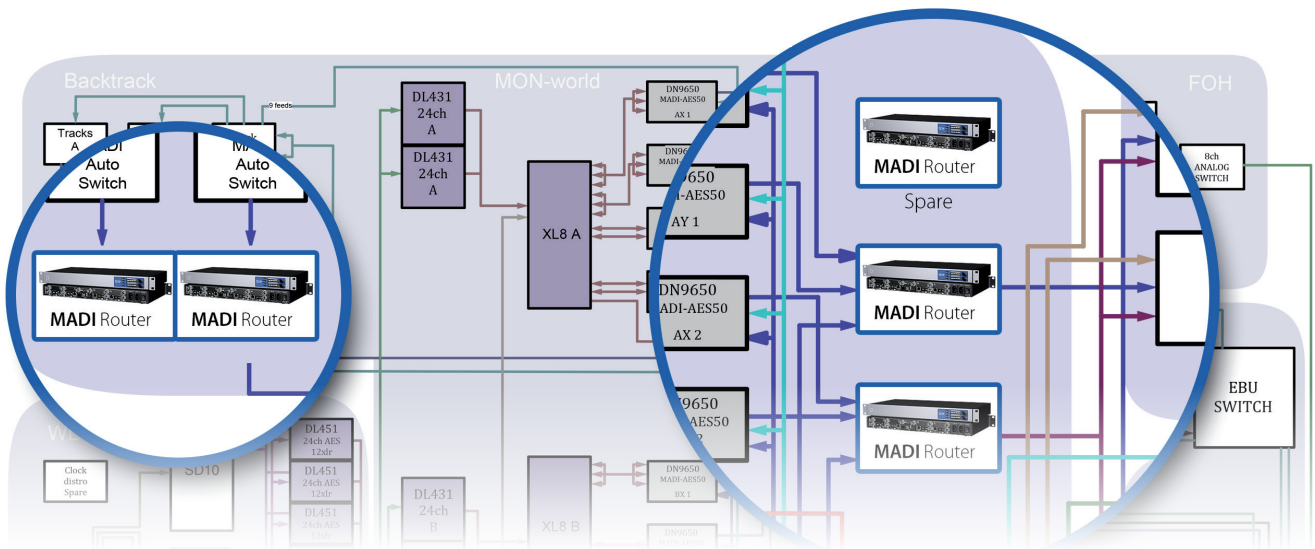

Connecting different audio „worlds“ at the Eurovision Song Contest 2014

Solution

Jurgen Vandewalle from Rent-All BV used the new RME MADI Routers for the Eurovision Song Contest 2014 in Copenhagen, Denmark.

„At the Eurovision Song Contest in Copenhagen I was responsible for the live sound reinforcement and audio distribution. In the hall we needed a MADI routing/distribution system for all the MADI streams among the different mixing desks from WL World, Backtrack, MON-world, FOH and the OB compound. (See schematics)

We used 5 units of the latest RME MADI Router generation. As you can imagine we couldn't afford any failures or other malfunctions. RME delivered what I expected and what I am used to. It worked immediately without any setup hassle and continued working flawlessly during setup, rehearsal, and main shows. Despite the small LCD screen, RME MADI Routers are very easy to operate. I didn't have to check them and could concentrate on all the other things instead.“

Additional information:

audio ag
Worldwide distributor of RME & AIVA

Audio AG
Am Pfanderling 60
85778 Haimhausen (Munich)
Germany

Phone: +49 8133 918170

Fax: +49 8133 9166

E-Mail: info@audioag.com

Web: www.audioag.com

RME

MADI Router Website:
<http://rme.to/mrouter>