

User's Guide



Micstasy

The Professional's Full Range Solution

TotalGain™

164 Option Slot™

AutoSet™

SteadyClock™

SyncCheck™

Professional Mic/Line/Instrument Preamp and AD-Converter
8-Channel Microphone / Line Preamp with Line Outputs
8-Channel Analog to AES / ADAT Interface
Optional 64-Channel MADI Interface
24 Bit / 192 kHz Digital Audio
MIDI Remote Control



AES-3
AES-10

24 Bit Interface

▶	Important Safety Instructions	4
---	--	---

▶ **General**

1	Introduction	6
2	Package Contents	6
3	Brief Description and Characteristics	6
4	First Usage – Quick Start	
4.1	Controls - Connectors - Displays	7
4.2	Quick Start	9
5	Accessories	9
6	Warranty	10
7	Appendix	10

▶ **Usage and Operation**

8	Front Panel Controls	
8.1	Select Key and Rotary Encoder (SET)	14
8.2	Clock Section	15
8.3	Analog Out	15
8.4	Remote.....	16
9	The Input Channel in Detail	
9.1	General	16
9.2	Gain.....	16
9.3	Phantom Power.....	16
9.4	Phase	17
9.5	M/S Processing.....	17
9.6	Lo Cut.....	17
9.7	AutoSet.....	18
9.8	HI Z.....	18
9.9	Instrument / Line	19
10	Presets	19
11	The Setup Menu	
11.1	General	20
11.2	Auto ID (Au)	20
11.3	Delay Compensation (dC).....	20
11.4	ID (Id)	21
11.5	Bank (bA)	21
11.6	Limiter Threshold (LI).....	21
11.7	Follow Clock (FC).....	22
11.8	Peak Hold (PH)	22
11.9	AutoSet Down-Link (AS dL)	22
11.10	Pro Tools MIDI Compatibility (pt)	23
11.11	Digital Output (do)	23
11.12	Word Clock Out (Co).....	23
11.13	Display Auto Dark (dArk)	24
11.14	Oscillator (oSC).....	24
12	Remote Control	
12.1	MIDI.....	25
12.2	MIDI over MADI.....	25
12.3	Remote Control Software.....	26

▶ **Inputs and Outputs**

13	Analog Inputs / Outputs	
13.1	Mic / Line In Rear.....	30
13.2	Instrument / Line In Front.....	30
13.3	Line Out	31
14	Digital Outputs	
14.1	AES / EBU	32
14.2	ADAT Optical	33
14.3	I64 MADI Card	34
14.4	Differences Micstasy / ADI-642	35
15	Word Clock	
15.1	Word Clock Input and Output	36
15.2	Technical Description and Background	37
15.3	Cables and Termination.....	38
16	MIDI	38

▶ **Technical Reference**

17	Technical Specifications	
17.1	Analog.....	40
17.2	Digital Inputs	41
17.3	Digital Outputs	42
17.4	Digital	42
17.5	MIDI	42
17.6	General	43
17.7	Firmware	43
17.8	MADI User Bit Chart	43
17.9	Connector Pinouts	44
18	Technical Background	
18.1	Terminology	46
18.2	Lock and SyncCheck	47
18.3	Level References and Gain	48
18.4	Latency and Monitoring	49
18.5	DS – Double Speed	50
18.6	QS – Quad Speed	50
18.7	AES/EBU – SPDIF	51
18.8	Signal to Noise ratio in DS- / QS-Operation	52
18.9	MADI Basics	53
18.10	SteadyClock.....	54
19	Block Diagram	55
20	MIDI Implementation Micstasy	
20.1	Basic SysEx Format	56
20.2	Message Types	56
20.3	Table	57
20.4	Pro Tools MIDI Compatibility	59
20.5	Yamaha MIDI Compatibility	60

Important Safety Instructions



ATTENTION! Do not open chassis – risk of electric shock

The unit has non-isolated live parts inside. No user serviceable parts inside. Refer service to qualified service personnel.



Mains

- The device must be earthed – never use it without proper grounding
- Do not use defective power cords
- Operation of the device is limited to the manual
- Use same type of fuse only



To reduce the risk of fire or electric shock do not expose this device to rain or moisture. Prevent moisture and water from entering the device. Never leave a pot with liquid on top of the device. Do not use this product near water, i. e. swimming pool, bathtub or wet basement. Danger of condensation inside – don't turn on before the device has reached room temperature.



Installation

Surface may become hot during operation – ensure sufficient ventilation. Avoid direct sun light and do not place it near other sources of heat, like radiators or stoves. When mounting in a rack, leave some space between this device and others for ventilation.



Unauthorized servicing/repair voids warranty. Only use accessories specified by the manufacturer.



Read the manual completely. It includes all information necessary to use and operate this device.

User's Guide



Micstasy

▶ General

1. Introduction

The Micstasy's innovative concept allows for amplification and digitization of ALL analog signal sources. Be it high-level stage signals, typical studio signals, lower level and high-impedance instruments, or dynamic, condenser or ribbon microphones: Micstasy understands them all – in a way that is simply thrilling.

When developing the Micstasy we used all our experience, and also the experience of our customers, to create a unique, excellent and high-quality unit. Although the Micstasy breaks into a price category which is quite unusual for an RME product, it still offers the typical, outstanding price/performance ratio known from RME. Micstasy's features will excite you – but even more the performance and smartness that it shows in solving any given task. Have fun!

2. Package Contents

Please check that your Micstasy package contains each of the following:

- Micstasy
- Power cord
- Manual
- RME Driver CD
- 1 optical cable (TOSLINK), 2 m

3. Brief Description and Characteristics

The Micstasy is a full range hi-end preamp and AD-converter in reference quality, fully remote controllable, with optional MADI I/O. In a standard 19" box with 2 unit height the device offers numerous extraordinary features like Intelligent Clock Control (ICC), SyncCheck[®], SteadyClock, TotalGain, AutoSet, MIDI over MADI, and remote control via MADI and MIDI.

- 8 balanced XLR mic/line inputs
- 85 dB gain range
- Analog input level from –56.5 dBu up to +30 dBu
- High-end circuitry with 4 relays per channel, super low-noise microphone front-end
- Large frequency range (200 kHz) with special EMI input filtering
- 8 balanced TRS line / instrument inputs
- 8 balanced XLR line outputs
- Symmetrical hi-pass (Lo Cut) with super-low THD, 18 dB/oct
- Hi-Z option per front input
- LED level meter with 13 LEDs per channel
- Near click-free gain changes
- Noise suppression on power-on and power-off at the analog outputs
- M/S encoding for the digital output
- AutoSet: Automatic gain reduction with multiple linking
- Current state can be stored to 8 user presets
- Fully remote controllable
- Word clock input and output
- SyncCheck tests and reports the synchronization status of the clock signals
- MIDI I/O
- 4 x AES/EBU Out per D-sub, 8 channels @ 192 kHz
- 2 x ADAT Out, 8 channels @ 96 kHz
- Optional MADI I/O (164 MADI Card)

4. First Usage – Quick Start

4.1 Controls - Connectors - Displays

The front of the Micstasy features eight instrument/line inputs, eight LED level meter, eight numerical LED displays, eight Select keys, a rotary encoder, further keys for more specific configuration options, and 69 LEDs providing a detailed status display.

Each channel has a dedicated configuration area on the front plate. The display **GAIN** shows the currently set amount of amplification. The 13-segment **LEVEL** meter with switchable Peak Hold function shows the AD-converter's input level.

The inputs **INST/LINE** accept both a balanced line signal as well as an unbalanced instrument signal via 1/4" TRS and TS plugs.

The **SELECT** button is used for a per-channel activation / deactivation of:

GAIN	Amount of amplification
+48V	Phantom power (XLR only)
PHASE	Phase reversal (180°)
M/S (D)	Mid/Side encoding (digital outputs only)
LO CUT	Subsonic/rumble filter
AUTOSET	Automatic gain reduction
HI Z	High input impedance for instruments
I	Activates the front INST/LINE jack

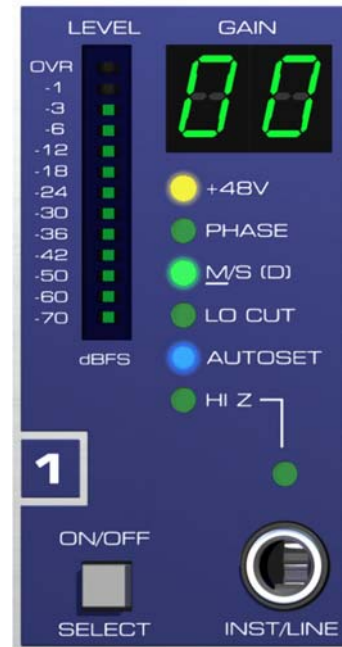

Pushing the knob **SET** several times lets you access all functions consecutively. The rotary encoder is a highly intuitive multifunctional device. It is used to set the gain, to select the desired function, to deactivate the function of one or all channels, to select a preset, and to select various options in the Setup menu.

The key **ANALOG OUT** defines the analog reference level at the analog outputs. This level is reached at full scale of the AD-converters, thus matching the front panel level meter's level indication.



REMOTE defines the source for MIDI remote control operation (Option Slot/MADI or DIN jack).

After pressing the **SAVE** button and selecting one of the 8 internal memories with the rotary encoder, the current channel settings will be stored as preset by pressing SAVE a second time.

After pressing the **RECALL** button, selecting a preset with the rotary encoder and pressing RECALL a second time, the selected preset is loaded and the state of the channels is updated.

In the **CLOCK SECTION** the current clock reference and frequency multiplier is chosen.

The rear panel of the Micstasy has eight analog inputs, eight analog outputs, mains power, MIDI I/O, word clock I/O, the I64 Option Slot, and all digital inputs and outputs (AES/ADAT).

MICROPHONE / LINE BALANCED INPUTS (XLR): Eight balanced *full range mic/line inputs* with 85 dB gain range.

LINE BALANCED OUTPUTS (XLR): Eight balanced **line outputs** with up to +27 dBu level.

AES I/O (25-pin D-sub): The D-sub connector provides four AES/EBU outputs (AD signals) and one AES/EBU input (clock synchronization). The 25 pin D-sub connector is wired according to the widely spread Tascam standard (pinout see chapter 17.9). The AES I/Os are transformer-coupled. The high sensitivity type input accepts all common digital sources, even SPDIF.

ADAT OUT (TOSLINK): Optical ADAT outputs. These provide the same signals as the AES/EBU outputs, but in ADAT format.



WORD IN (BNC): A push switch allows to activate internal termination (75 Ohms).

WORD OUT (BNC): Standard word clock output.

MIDI I/O (5-pin DIN): MIDI input and output via 5-pin DIN jacks. Used to remote control the Micstasy, and – with installed MADi Card - to transmit MIDI data via MADi.

IEC receptacle for power connection. The specially developed, internal hi-performance switch mode power supply lets the Micstasy operate in the range of 100V to 240V AC. It is short-circuit-proof, has an integrated line-filter, is fully regulated against voltage fluctuations, and suppresses mains interference.

With installed **I64 MADi Card**:

MADi I/O optical: Standard MADi ports.

MADi I/O coaxial (BNC): Standard MADi ports.

4.2 Quick Start

After connection of all cables and power-on of the device, the configuration of the Micstasy begins in the CLOCK section. Choose a clock source and a sample rate. The next step is the GAIN setting. This can be done in two ways:

- Individually: Hit the SELECT button of one or several channels. The corresponding GAIN displays start flashing. Select the desired value with the rotary encoder. Or:
- Globally: Push the encoder knob once. All GAIN displays start flashing. Select the desired value with the rotary encoder.

The flashing stops automatically after about six seconds. The LEVEL meter serves as comfortable tool to check whether gain is sufficient or already overloading the input.

To activate a function, press the SET knob repeatedly until the corresponding LEDs are flashing. Pressing once all GAIN displays start flashing (gain setting), pressing twice selects all +48V, then PHASE and so on. To activate or deactivate a specific function per channel, the corresponding **SELECT** button is used. They are therefore also labelled ON/OFF.

The Micstasy stores all settings before switching off, and sets them automatically when switching on the next time. The storing process is triggered 4 seconds after the last change, and is signalled in the Gain display as quickly moving point.

5. Accessories

RME offers several optional components for the Micstasy:

Part Number	Description
OK0050	Optical cable, Toslink, 0.5 m (1.7 ft)
OK0100	Optical cable, Toslink, 1 m (3.3 ft)
OK0200	Optical cable, Toslink, 2 m (6.6 ft)
OK0300	Optical cable, Toslink, 3 m (9.9 ft)
OK0500	Optical cable, Toslink, 5 m 16.4 ft)
OK1000	Optical cable, Toslink, 10 m (32.8 ft)
BO25MXLR4M4F1PRO	Digital Breakout Cable Pro, AES/EBU 25-pin D-sub to 4 x XLR male + 4 x XLR female, 1m (3.3 ft)
BO25MXLR4M4F3PRO	same, 3 m (9.9 ft)
BO25MXLR4M4F6PRO	same, 6 m (19.8 ft)
BO25M25M1PRO	Digital D-sub cable Pro, AES/EBU 25-pin D-sub to 25-pin D-sub, 1m (3.3 ft)
BO25M25M3PRO	same, 3m (9.9 ft)
BO25M25M6PRO	same, 6m (19.8 ft)
I64 MADI Card	MADI module featuring thru-input, Delay Compensation, Auto ID, MIDI over MADI, remote via MADI
BOB32	BOB-32, Universal breakout box, 19" 1 Unit height. The professional digital AES/EBU breakout solution

6. Warranty

Each individual Micstasy undergoes comprehensive quality control and a complete test at IMM before shipping. The usage of high grade components should guarantee a long and trouble-free operation of the unit.

If you suspect that your product is faulty, please contact your local retailer.

Audio AG grants a limited manufacturer warranty of 6 months from the day of invoice showing the date of sale. The length of the warranty period is different per country. Please contact your local distributor for extended warranty information and service. Note that each country may have regional specific warranty implications.

In any case warranty does not cover damage caused by improper installation or maltreatment - replacement or repair in such cases can only be carried out at the owner's expense.

No warranty service is provided when the product is not returned to the local distributor in the region where the product had been originally shipped.

Audio AG does not accept claims for damages of any kind, especially consequential damage. Liability is limited to the value of the Micstasy. The general terms of business drawn up by Audio AG apply at all times.

7. Appendix

RME news and further information can be found on our website:

<http://www.rme-audio.com>

Distributor: Audio AG, Am Pfanderling 60, D-85778 Haimhausen, Tel.: (49) 08133 / 91810

Manufacturer:

IMM Elektronik GmbH, Leipziger Strasse 32, D-09648 Mittweida

Trademarks

All trademarks and registered trademarks belong to their respective owners. RME, SyncAlign, Hammerfall, DIGICheck, SyncCheck and ZLM are registered trademarks of RME Intelligent Audio Solutions. TotalGain, SteadyClock, Micstasy, I64 Option Slot, I64 MADI Card and Intelligent Clock Control (ICC) are trademarks of RME Intelligent Audio Solutions. Alesis and ADAT are registered trademarks of Alesis Corp. ADAT optical is a trademark of Alesis Corp. S/MUX is copyright Sonorus. Digidesign and Pro Tools are trademarks or registered trademarks of Avid Technology, Inc.

Copyright © Matthias Carstens, 04/2011. Version 1.7

All entries in this User's Guide have been thoroughly checked, however no guarantee for correctness can be given. RME cannot be held responsible for any misleading or incorrect information provided throughout this manual. Lending or copying any part or the complete manual or its contents as well as the software belonging to it is only possible with the written permission from RME. RME reserves the right to change specifications at any time without notice.

CE / FCC Compliance

CE

This device has been tested and found to comply with the limits of the European Council Directive on the approximation of the laws of the member states relating to electromagnetic compatibility according to RL2004/108/EG, and European Low Voltage Directive RL2006/95/EG.

FCC

This equipment has been tested and found to comply with the limits for a Class B digital device, pursuant to Part 15 of the FCC Rules. These limits are designed to provide reasonable protection against harmful interference in a residential installation. This equipment generates, uses, and can radiate radio frequency energy and, if not installed and used in accordance with the instructions, may cause harmful interference to radio communications. However, there is no guarantee that interference will not occur in a particular installation. If this equipment does cause harmful interference to radio or television reception, which can be determined by turning the equipment off and on, the user is encouraged to try to correct the interference by one or more of the following measures:

- Reorient or relocate the receiving antenna.
- Increase the separation between the equipment and receiver.
- Connect the equipment into an outlet on a circuit different from that to which the receiver is connected.
- Consult the dealer or an experienced radio/TV technician for help.

RoHS

This product has been soldered lead-free and fulfils the requirements of the RoHS directive.

ISO 9001

This product has been manufactured under ISO 9001 quality management. The manufacturer, IMM Elektronik GmbH, is also certified for ISO 14001 (Environment) and ISO 13485 (medical devices).

Note on Disposal

According to the guide line RL2002/96/EG (WEEE – Directive on Waste Electrical and Electronic Equipment), valid for all european countries, this product has to be recycled at the end of its lifetime.

In case a disposal of electronic waste is not possible, the recycling can also be done by IMM Elektronik GmbH, the manufacturer of the Micstasy.

For this the device has to be sent **free to the door** to:

IMM Elektronik GmbH
Leipziger Straße 32
D-09648 Mittweida
Germany



Shipments not prepaid will be rejected and returned on the original sender's costs.



User's Guide



Micstasy

▶ Usage and Operation

8. Front Panel Controls

8.1 Select Key and Rotary Encoder (SET)

The rotary encoder **SET** is a highly intuitive multifunctional device. It is used to set the gain, to select the desired function, to deactivate the function of one or all channels, to select a preset, and to select various options in the Setup menu.

To activate a function, press the knob repeatedly until the corresponding LEDs are flashing. Pressing once all GAIN displays start flashing (gain setting), pressing twice selects all +48V, then PHASE and so on*.

To activate or deactivate a specific function per channel, the corresponding **SELECT** button is used. They are therefore also labelled ON/OFF.

Each channel offers the following functions:

GAIN	Amount of amplification
+48V	Phantom power (XLR only)
PHASE	Phase reversal (180°)
M/S (D)	Mid/Side encoding (digital outputs only)
LO CUT	Subsonic/rumble filter
AUTOSET	Automatic gain reduction
HI Z	High input impedance for instruments
I	Activates the INST/LINE jack

Setting the GAIN can be done in two ways:

- Individually: Hit the SELECT button of one or several channels. The corresponding GAIN displays start flashing. Select the desired value with the rotary encoder. Or:
- Globally: Push the encoder knob once. All GAIN displays start flashing. Select the desired value with the rotary encoder.

When adjusting several channels at the same time, the relation between individual channels will be retained. So the gain of multiple channels can be increased or decreased without them losing their level relations. In case one of the linked channels reaches the highest or lowest gain value (-9 or +76.5 dB), the gain relationship gets lost.

Turning the encoder knob to the left initiates a global OFF command for all selected (flashing) channels. For example, Phantom power can be switched off for all channels by pressing the encoder knob twice and then turning it to the left.

For safety reasons, the corresponding global ON command (a turn to the right) has only been implemented for the AutoSet function.

Also for safety reasons, the Micstasy will leave the selected function after 6 seconds. This may seem cumbersome when changing the gain frequently, because the gain function will have to be selected every time via the Select button or the encoder first. On the other hand, the Micstasy is absolutely safe from accidental changes.

* The factory default order when stepping through the functions is as described. Hold Select button 8 pressed from power-on until the Gain displays show up to change the order of Hi Z and I. The factory default mode is set by holding Select button 7 on power-up.

8.2 Clock Section

The source and frequency of the unit's clock is configured in the CLOCK SECTION. The button CLOCK lets you step through the options external clock (Word, AES, Option = MADI) and internal clock. The button SAMPLE RATE sets the sample rate for both external and internal clock.

WCK, AES, OPTN (Slave Mode)

Defines the corresponding input as clock reference. A missing or invalid clock source signal is indicated by flashing of the corresponding LED.

INT (Master Mode)

Activates the internal clock.



With a setting of INT (internal clock) it is mandatory that the clock rate of the sources is synchronous to the Micstasy. Therefore the external device has to be synchronized to the Micstasy word clock output or AES/ADAT/MADI output.

The Micstasy thus has to be master, all devices connected to it must be slave. In order to avoid clicks and drop outs due to faulty or missing synchronicity, a special process called *SyncCheck* compares the incoming data and the Micstasy internal clock. The SYNC state is indicated by a flashing (error) or turned off (OK) LED.

44.1, 48

Activates the internal clock at 44.1 kHz or 48 kHz.

DS, QS

With the DS LED additionally lit, the sample rate will be 88.2 or 96 kHz, with QS lit it will be 176.4 or 192 kHz.

A selection of DS and QS is also possible when using external clock (Slave). If the Micstasy should operate at 192 kHz, but receives a synchronous word clock of 48 kHz, the button SAMPLE RATE allows to activate DS or QS mode. This way, AD-conversion and digital outputs are configured to operate in the frequency ranges Single Speed, Double Speed or Quad Speed.

Single Speed

All outputs carry a signal in the range of 32 kHz up to 48 kHz.

DS (Double Speed)

The AES outputs 1-8 carry a signal in the range of 64 kHz up to 96 kHz. ADAT and MADI stay at no higher than 48 kHz, with the data transmitted in the S/MUX format.

QS (Quad Speed)

The AES outputs 1-8 carry a signal in the range of 176.4 kHz up to 192 kHz. ADAT and MADI stay at no higher than 48 kHz, with the data transmitted in the S/MUX4 format. Therefore ADAT is limited to 4 channels (2 per optical output) in this mode.

8.3 Analog Out

The button **ANALOG OUT** is used to set the analog reference level at the analog outputs. This level is reached at full scale of the AD-converters, thus matching the front panel level meters level indication.

Reference	0 dBFS @	Analog Headroom
+24	+24 dBu	3 dB
+19	+19 dBu	8 dB
+13	+13 dBu	14 dB

8.4 Remote

REMOTE defines the source of MIDI remote control commands. Choices are the MIDI DIN jack and the MADI input of the I64 MADI Card (Option Slot).

Note: Via MIDI remote control, all front panel controls can be locked (Lock Keys). An exception is the REMOTE key. In Off-state Lock Keys is deactivated. Therefore a locking of all the controls can be revoked directly at the unit at any time.

9. The Input Channel in Detail

9.1 General

Each channel has a dedicated configuration area on the front plate. The display **GAIN** shows the currently set amount of amplification. The 13-segment **LEVEL** meter with switchable Peak Hold function shows the AD-converter's input level. The **SELECT** button is used to select a channel, but also to activate/deactivate the different functions (Phase, Lo Cut etc).

9.2 Gain

The Micstasy **GAIN** can be set in steps of 0.5 dB per channel. Setting the amount of amplification is done digitally, therefore being very accurate and 100% reproducible. The gain change itself is performed within the analog domain.

Using the rear full range XLR input, the gain can be set over a range of 85.5 dB. The AD-converter in the Micstasy reaches full scale already at an input level of -56.5 dBu (GAIN display 76.5), but also at $+30$ dBu (GAIN display -09). Therefore the rear input is both a sophisticated microphone and line input. Using it as line input, its impedance of 2 kOhm, optimized for microphones, should be noted. In practise, using modern devices, this should not cause any problem. Devices with high-impedance outputs will show a small loss of level, which can be compensated easily with the Gain control – if necessary at all.

Sources with higher output impedances (e.g. consumer CD-player) are better served using the front TRS input, as this one has an impedance of 5.6 kOhm, with Hi-Z on even 470 kOhm.

At the front input, gain can be set over a range of 50 dB. The upper level limit is $+21$ dBu, therefore the GAIN display starts at 00 and ends at 50. Changing from the rear to the front input, the gain setting changes automatically in case the current value had been outside the range available on the front.

9.3 Phantom Power

The LED **+48V** indicates activated phantom power for the XLR input. Phantom power should only be activated when using condenser microphones which require such a power supply.



Connecting and disconnecting microphones while phantom power is active causes a high voltage surge, which can destroy the microphone input stage! Switch phantom power off before connecting/disconnecting any external device.

The Micstasy turns on the phantom power smoothly during one second, from 0 to 48 Volts. This technique is advantageous for the connected microphone as well as the Micstasy.

The phantom power of the Micstasy is short-circuit proof. With a maximum load on all eight channels the internal voltage from the power supply does not drop below 47 Volts.

9.4 Phase

PHASE changes the polarity (180°). Phase cancellations and sound changes can be caused by using multiple microphones at different places, or wrongly soldered cables. In such cases PHASE can eliminate the error by adding an additional phase inversion.

The signal path of the Micstasy is fully symmetrical, from the input up to the AD-converter. Therefore the function Phase is realized passively by a simple relay, swapping the positive and negative signal line. With this, Phase operates fully transparent and causes zero change of the audio signal.

9.5 M/S Processing

The mid/side principle is a special positioning technique for microphones, which results in a mid signal on one channel and a side signal on the other channel. These information can be transformed back into a stereo signal quite easily. The process sends the monaural mid channel to left and right, the side channel too, but phase inverted (180°) to the right channel. For a better understanding: the mid channel represents the function L+R, while the side channel represents L-R.

The Micstasy includes a digital M/S processor. Therefore the analog output signal stays unchanged. Also the channels have a fixed assignment: all odd ones are M, all even ones are S. The front panel shows an according labelling:

Channel 1 M/S (D)

Channel 2 M/S (D)

The M/S-Processing automatically operates as M/S encoder or decoder, depending on the source signal format. When processing a usual stereo signal, all monaural information will be shifted into the left channel, all stereo information into the right channel. Thus the stereo signal is M/S encoded. This yields some interesting insights into the mono/stereo contents of modern music productions. Additionally some very interesting methods of manipulating the stereo base and generating stereo effects come up, as it is then very easy to process the side channel with Low Cut, Expander, Compressor or Delay. The most basic application is to change the level of the side channel: this allows to manipulate the stereo width from mono to stereo up to extended in a step-less way.

9.6 Lo Cut

LO CUT activates a high-pass (bass removal) with 18 dB per octave, at a cut-off frequency of 65 Hz. This filter can remove rumble, subsonic-noise and other low frequency noises.

The LO CUT of the Micstasy shows a slow roll-off in the frequency response, without any resonance rise. The circuit design provides low THD figures, which unfortunately is not taken for granted. Even very expensive devices sometimes incorporate Lo Cut filters that cause relatively high distortion of about 1%. The basic filter of the Micstasy is THD optimized. It generates even at already low 20 Hz a distortion of only 0.13 %. Note that here the fundamental signal is already attenuated by 34 dB. The special symmetrical design with two filters further lowers the distortion to 0.08 %. At the same time linearity and noise are improved. At 30 Hz and 22 dB attenuation the distortion is down to 0.03 %. Thus the sum of all generated harmonics is 69 dB below the fundamental, which is again already lowered by 22 dB – and is therefore without any meaning.

9.7 AutoSet

Some preamps include limiters in order to prevent clipping, especially of the A/D converter stage. Such a circuitry is not feasible for the Micstasy, because it would spoil the mic preamp's excellent technical data.

But as the Micstasy's gain is controlled completely digitally, the device can set it automatically, thus providing perfect protection from overload with no degradation of the audio signal, which does not have to pass any additional electronic circuits.

Since AutoSet operates as overload protection and not as 'compressor', there is no automatic gain increase. AutoSet only reduces gain. In the Setup menu, the threshold level beyond which the gain will be reduced can be adjusted in four steps (-1, -3, -6, -12 dBFS). Any change of gain will be shown immediately on the GAIN displays. And with AutoSet activated, the gain can still be changed manually. The currently highest possible value can not be exceeded, because AutoSet will reduce the gain in real-time during the manual change.

In practice, there are two possible ways to work with AutoSet:

- Gain of all channels is set to a rather high value, e.g. 60 dB. Then a rehearsal with maximum acoustic level is performed. Thereafter AutoSet is switched off.
- As above, with AutoSet permanently active.

There are good reasons for both of these alternatives. Thanks to the flexible threshold setting and easy manual correction of set values, the Micstasy is fit for all applications.

The values set by AutoSet can easily be changed globally, or for individual or multiple channels, without changing the gain relation between channels. Pressing the encoder knob will make all gain displays flash. Turning the encoder left or right will decrease or increase the gain values by any desired value (in dB).

AutoSet allows single or multiple channels to be linked with the channel to the left. More information can be found in chapter 11.9, AutoSet Down-Link.

AutoSet reduces gain by about 20 dB in 10 ms. Under certain level states, this can lead to a short clipping of the AD-converter. In practical tests, we found it hard to detect these clippings. This is only possible with sustained signals including extreme level jumps, and is comparatively harmless even in these cases. Additionally AutoSet does not cause any of the control noises known from usual Limiters, SNR and THD stay completely unchanged. Just try it out - AutoSet will convince you too!

Micstasy remembers all settings when it is switched off. The AutoSet state is also included when storing to a preset. However AutoSet is always deactivated after the device is switched on, to prevent accidental changes of previously determined gain values.

Note: AutoSet is the only function that can be globally activated via SET and a right turn of the encoder knob.

9.8 HI Z

The front input **INST/LINE** has an input impedance of 5.6 kOhm. Connecting passive instruments like bass and guitar, an activation of HI Z changes the input impedance to 470 kOhm, providing perfect conditions for these types of signal sources.

9.9 Instrument / Line

The **INST/LINE** inputs allow to attach both balanced line signals as well as unbalanced instrument signals via 1/4" TRS jacks. It handles standard line sources like keyboards, mixing desks, effects devices or consumer-type units perfectly well. Changing the input impedance to Hi Z (470 kOhm instead of 5.6 kOhm) turns INST/LINE into a perfect instrument input.

The input Inst/Line operates fully servo-balanced even with HI Z activated.

The maximum input level is +21.5 dBu unbalanced and +27.5 dBu balanced. The latter can only be used with the analog output, as the AD-converter reaches full scale level at exactly +21 dBu.

Inst/Line uses an active servo-balanced input stage that is added in front of the microphone input. The circuit uses an innovative design with particularly low-noise op-amps. Nevertheless it is needless to say that one can't prevent a higher noise at higher gain settings, when comparing the front with the rear input. In practice this usually stays unnoticed, as the sources generate much more noise than the Micstasy.

Because of the lower maximum level the GAIN display starts at 00, and because of the higher self-noise it ends at 50. Changing from the rear to the front input, the gain setting changes automatically in case the current value had been outside the range available on the front.

10. Presets

The channel settings of the Micstasy can be stored to eight different user presets. The settings performed in the right side of the front panel are not stored: Clock, Sample Rate, Analog Out and Remote. This way, the channel settings can be used with different clocking and independent from the current operating situation (front panel or remote operation).

After pressing the **SAVE** button and selecting one of the 8 internal memories with the rotary encoder, the current channel settings will be stored as preset by pressing SAVE a second time.

After pressing the **RECALL** button, selecting a preset with the rotary encoder and pressing RECALL a second time, the selected preset is loaded and the state of the channels is updated.

Note: The keys SAVE and RECALL provide an exit functionality. When Save is pushed a second time without turning the encoder knob first (no preset is selected), the Save process will be exited immediately. Recall acts in the same way. As one can change from any function directly to Save and Recall by pushing these buttons, ANY setup process can be exited immediately by a quick double-push on either Save or Recall. Also it is not necessary to wait 6 seconds until the flashing stops or the setup menu is exited automatically – just do the double-push.

11. The Setup Menu

11.1 General

Some options and settings are accessed and changed very seldom. These have been collected in the Setup menu.

The Setup menu is entered by pushing SAVE and RECALL at the same time. All changes are stored automatically.

11.2 Auto ID (Au)

Default: Off

Available settings: On, Off

This option relates to the use of the I64 MADI Card. Multiple Micstasy (and ADI-642 and ADI-8 QS, see chapter 14.4) connected serially can assign consecutive IDs to themselves (see chapter 11.4). For this to happen, Auto ID is set to On at the first device of the chain. All other devices automatically turn into slaves. An Auto ID slave has the middle dot lit in the GAIN display of channel 8.

11.3 Delay Compensation (dC)

Default: Off

Available settings: On, Off

This option relates to the use of the I64 MADI Card. When multiple devices are connected serially, the MADI I/O of each Micstasy causes a delay of 3 samples. Therefore at the MADI output of the last device, the data of all upstreamed devices are delayed. At Double Speed the delay rises to 6 samples per unit, at Quad Speed to 12 samples.

The problem of this offset is solved by the function *Delay Compensation*. It delays the signals in a way that they are sample-synchronous in multi-device operation. Attention: Delay Compensation has to be manually activated in each unit!

The following table lists the delay in samples from two up to eight units connected serially. When using four units, the data of the first unit are delayed by 9 samples to the last unit, the units 2 and 3 are delayed by 6 and 3 samples respectively. At Double Speed and Quad Speed the values rise. Please note that in Double Speed no more than four, in Quad Speed no more than two Micstasy can be used serially with MADI.

Units	Delay	Delay DS	Delay QS	DC	DC DS	DC QS
2	3	6	12	21	18	12
3	6	12	-	21	18	-
4	9	18	-	21	18	-
5	12	-	-	21	-	-
6	15	-	-	21	-	-
7	18	-	-	21	-	-
8	21	-	-	21	-	-

21 samples @ 48 kHz
equal 437 µs.

18 samples @ 96 kHz
equal 187 µs.

12 samples @ 192
kHz equal 62.5 µs.

As shown in the table, activating DC causes a constant delay of 21 samples in Single Speed, no matter how many devices are connected serially. In Double Speed the delay is 18, in Quad Speed 12 samples. The in most cases slightly increased delay is outweighed by the big advantage of sample-aligned I/Os when using multiple units.

Delay Compensation always uses the worst case, the operation of 8 units, but delays the signals individually. The amount of the respective delay is solely derived from the current ID, no matter if it has been assigned manually or by Auto ID.

11.4 ID (Id)

Default: 01

Available settings: 01, 02, 03, 04, 05, 06, 07, 08

To remote control more than one Micstasy each device can have its own ID, providing a separated remote control of multiple devices via a single MIDI channel.

164 MADI Card: The ID defines the 8-channel group within the MADI signal that is used to insert the device's audio data:

ID 01: channels 1-8	ID 02: channels 9-16	ID 03: channels 17-24
ID 04: channels 25-32	ID 05: channels 33-40	ID 06: channels 41-48
ID 07: channels 49-56	ID 08: channels 57-64	

When several Micstasy, ADI8-QS or ADI-642 units are connected via MADI, Auto ID normally takes care of the channel assignment (see chapter 11.2, Auto ID). In special cases, it may be desirable to set the ID manually, e.g. if the first device in a MADI chain does not support the Auto ID mode, or if a group of eight channels needs to be routed or processed in a particular way.

With activated mode *Digital Out* the ID also defines which MADI input channels are sent to the ADAT/AES outputs, see chapter 11.11.

Note: When the device is *Auto ID Slave*, the displayed ID can not be changed manually.

11.5 Bank (bA)

Default: 01

Available settings: 01, 02, 03, 04, 05, 06, 07, 08

To remote control more than one Micstasy each device can have its own ID, providing a separated remote control of multiple devices via a single MIDI channel. Additionally, not only 8 IDs but 8 banks of 8 IDs each are available.

11.6 Limiter Threshold (LI)

Default: 06

Available settings: 01, 03, 06, 12

Adjusting the threshold for the function AutoSet. Available values are -1, -3, -6 and -12 dBFS. As soon as the current value is met, AutoSet starts to reduce the Gain. This way a headroom equalling the threshold value is created, because the level can not be higher than the current value.

11.7 Follow Clock (FC)

Default: Off

Available settings: On, Off

The signal at the word clock or AES input can be Single, Double or Quad Speed, the Micstasy can use it in any case, independent of its current clock range. When activating the option *Follow Clock* the Micstasy follows the input clock 1:1. At 96 kHz the DS LED will light up automatically, at 192 kHz the QS LED. This function is automatically deactivated for the I64 MADI Card, as it is not possible to detect the sample rate range of the MADI-embedded audio data.

11.8 Peak Hold (PH)

Default: Off

Available settings: On, Off

The level meter can be configured to hold the peak value permanently. A reset is done by turning the Encoder, also when no other function had been selected before.

11.9 AutoSet Downlink (AS dL)

Default: None

Available settings: Channel 1 up to 7 via Select key

The AutoSet feature would not be complete without a way to link several channels to avoid changes of volume (surround) or panorama (stereo).

AutoSet can be linked with one or more channels to the left of any given channel. After activating AS dL in the Setup menu, the eight Select buttons are used for configuration. The following three examples will illustrate this:

- Select channel 5, the blue AutoSet LED of channel 5 lights up. Channels 4 and 5 are now linked.
- Select channels 5 and 4. The AutoSet LEDs for channels 5 and 4 light up. Channels 5, 4, and 3 are linked.
- Select channels 8 and 7. The AutoSet LEDs for channels 8 and 7 light up. Channels 8, 7 and 6 are linked. This 'group' will operate independently of the other group (5/4/3).

Thus, up to 4 independent stereo pairs and two groups of multiple channels can be set up, all of which will work independently.

When leaving the AutoSet menu and selecting AutoSet, the LEDs of all channels with active AutoSet will light up. The only way to determine whether channels are linked or not is to open the Setup menu.

Even when Downlink is activated, the values determined by AutoSet can be changed manually without changing relative levels. To do so, all linked channels must be selected when changing gain.

11.10 Pro Tools MIDI Compatibility (Pt)

Default: Off

Available settings: On, Off

The Micstasy is MIDI remote compatible to Digidesign's Pro Tools system. The extended functionality of the Micstasy (e.g. much smaller gain steps) is not available here, because the Digidesign protocol does not support those features.

The Pro Tools micpre MIDI protocol uses simple controller messages and is therefore unprotected. Other MIDI devices like keyboards etc. shall not be active on the same MIDI line, otherwise certain values within the Micstasy will most probably be changed randomly. Because of this, the Pro Tools compatibility is switched off by default.

11.11 Digital Output (do)

Default: An

Available settings: An, oP

This option relates to the use of the I64 MADI Card. In default state (An) the analog input signal is available at all three digital outputs. Selecting oP (Option) an eight-channel group of the MADI input signal is sent to the ADAT/AES outputs. With this the MADI connection can also be used as return path. Sending audio via MADI to the Micstasy, the audio becomes available at the Micstasy's digital outputs ADAT/AES. The MADI output continues to carry the analog input signals and the fed-through input data.

Note: The 8-channel group sent to ADAT/AES is defined by the currently chosen ID.

11.12 Word Clock Out (Co)

Default: FS

Available settings: Si, FS

Si stands for Always Single Speed, FS for the current sample rate or Follow Sample rate. In default state (FS) the word clock output follows the current sample rate up to 192 kHz. Selecting Si causes the word clock output to always stay within the range of 32 kHz to 48 kHz. So at 96 kHz and 192 kHz sample rate, the output word clock is 48 kHz.

Note: A reliable sample-accurate synchronicity between multiple devices having digital interfaces in S/MUX technology (ADAT and MADI*) at sample rates in the Double Speed and Quad Speed range is only possible when all units are synced by Single Speed word clock. Because of the S/MUX method the device else can not know which of the incoming 2 (DS) or 4 (QS) word clock edges is the right one.

* With the Micstasy this limitation is also valid for the AES output, as the device internally handles all the data streams in S/MUX mode.

11.13 Display Auto Dark (dArk)

Default: Off

Available settings: On, Off

Displays and LEDs on the front panel can be switched off by activating the option *Display Auto Dark*. Only the decimal points from the 8 numerical LED displays will be lit. Such a mode is useful e. g. on stage.

Dimming takes place 10 seconds after the function has been activated. At the same time all control elements are momentarily locked, the device is therefore protected against unintentional changes. The combination Save-Recall (Setup menu) is not affected. All other keys can also be activated temporarily by keeping them pushed for a short time.

Note: dArk is available since firmware version 2.1.

11.14 Oscillator (oSC)

Default: Off

Available settings: On, Off

With bigger setups it can be difficult to follow the exact routing and signal path. The signal generator built into the Micstasy simplifies this task significantly. Choose oscillator (oSC) and activate this option by pushing one of the 8 Select keys. A square wave signal of approximately 180 Hz at a level of -30.1 dBFS will be generated and displayed immediately. Push the same button again to switch the oscillator off.

With activated test tone the numerical display of the corresponding channel will show 'to' (test oscillator) instead of the Gain value.

Note: oSC is available since firmware version 2.1.

12. Remote Control

12.1 MIDI

The Micstasy can be completely remote controlled via MIDI. It reacts on special SysEx commands. Furthermore, upon request it will report the complete device status, including all controls and LEDs on the front plate. Each Micstasy can be programmed with its own ID, providing a separated remote control of multiple devices via a single MIDI channel. A description of the MIDI implementation is found in chapter 20.

The button REMOTE is used to select the source of the MIDI remote control commands: MIDI port, MADI port and Off. The latter is a safety function to prevent any setup-change by any MIDI signal.

With an installed I64 MADI Card the Micstasy can also be remote controlled via MADI. Status information of the unit is sent to all outputs simultaneously. With an installed I64 MADI Card this includes embedded information at the MADI outputs (see 12.2, MIDI over MADI).

The diagram shows the signal flow of the MIDI data with all I/Os. The MIDI input signal reaches both the internal Remote Command Processor and the MIDI outputs. This *MIDI Through* function provides the base for a simplified serial MIDI cabling when using multiple Micstasy. The same is true for remote control via MADI, where MIDI is passed through from device to device automatically via the serial MADI cabling.

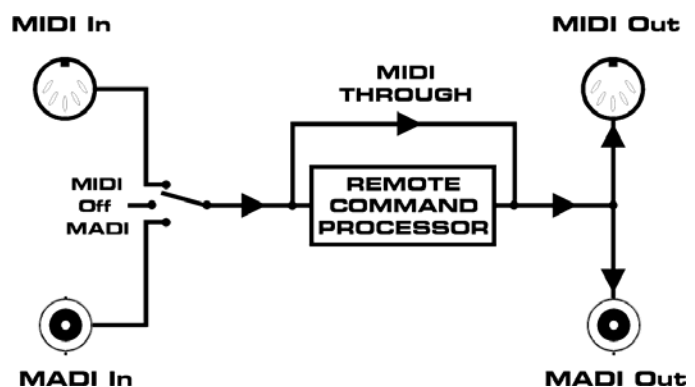

Since firmware 2.0 the Micstasy also reacts on Sysex commands from Yamaha's mixing desk PM5D. Adjustable are in this case: Input Gain in steps of 1 dB (gain range -9 up to +63 dB) and Phantom power per channel. For DM-1000 and DM-2000 see chapter 20.5.

12.2 MIDI over MADI

MADI allows for a transmission of 64 audio channels over long distances with a single line – perfect. But what about MIDI? Be it remote control commands or sequencer data, in practice only a single MADI line will not suffice. Daher entwickelte RME die *MIDI over MADI* Technologie. The data at the MIDI input are being included into the MADI signal invisibly, and can be collected at the MIDI output of another Micstasy, ADI-6432, ADI-642, ADI-648, ADI-8 QS or a HDSP MADI, at the other end of the MADI line.

Technically every single MADI channel includes several additional bits, containing various information (Channel Status). RME use the usually unused *User bit* of channel 56 (channel 28 in 96k frame mode), to transmit MIDI data invisibly within MADI, ensuring full compatibility.



Unlike other MADI-based devices from RME, the Micstasy is no bi-directional MIDI to MADI converter, because only one direction is available for the transmission.

The block diagram shows the signal flow in a HDSP MADI-based remote control system. MIDI commands from a software on PC or Mac travel from the MADI Out of the HDSP MADI to the MADI In as well as to the MIDI Out and MADI Out of the Micstasy.

Additional to the remote commands further MIDI data can be transmitted, available then at the DIN MIDI output jack of the Micstasy. However, MIDI signals at the DIN input jack can not travel back to the computer. With input setting MIDI the other direction is active. MIDI data travel from the MADI out to the computer, but not back from the computer via MADI to the Micstasy.

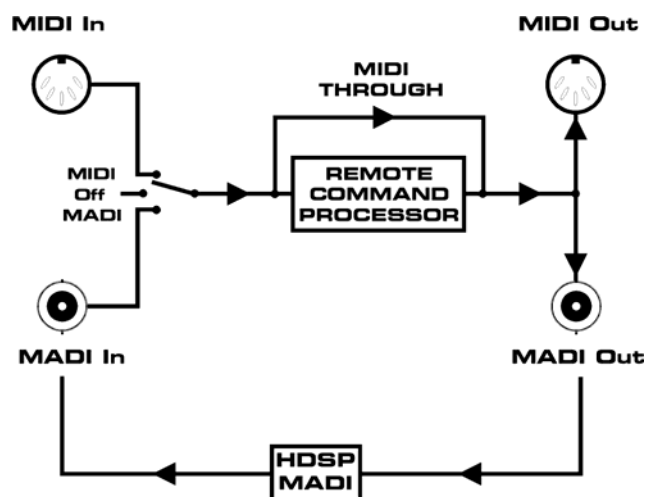

12.3 Remote Control Software

A free remote software for Windows and Mac OS X can be downloaded from the RME website. It can use any existing MIDI port within the system to perform remote control and status requests of any number of Micstasy via a simple mouse click. Most appealing is the combination with a HDSP(e) MADI, offering a direct control of the Micstasy via MADI. The remote control software then uses a virtual MIDI port of the card, which directly sends and receives MIDI data via MADI.

Software download: http://www.rme-audio.de/en_download.php

Brief description of the Windows/Mac OS X Software Micstasy MIDI Remote

The program includes an extensive english online help (F1). After the start first choose the function **Micstasy Front View** in the menu **Functions** (also available via F4).

Then select a MIDI input and output via **Options - MIDI I/O Setup**.

Using the command **Options – Start/Stop MIDI I/O** the communication with the Micstasy is started. The top line of the program window shows the current state, like selected ID, Online / No Response / Offline etc.

Save Workspace as allows to store complete setups including all windows in a file, and to reload them at any time.

Send Single Set of Data allows an offline configuration of the Micstasy, and uses a single one-time transmission of all settings.

The **Micstasy Front View** equals to a large extent the front panel of the unit. In some places the operational concept has been slightly changed. E.g. as there is no push encoder, the global selection is done via holding down the Ctrl key.

The settings of the Setup menu are available directly on the surface. The current AutoSet **Downlink** configuration is also directly displayed, and therefore in direct control all the time.

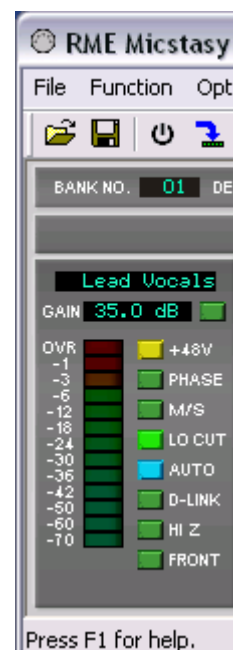

Names can be assigned to all channels and all devices.

Via MIDI remote control, all front panel controls of the Micstasy can be locked (**Lock Keys**). An exception is the REMOTE key. In the Off-state the function Lock Keys is deactivated. Therefore a locking of all the controls can be revoked directly at the unit at any time.

The unique multi-window concept of the software MIDI Remote allows for a simultaneous usage and configuration not only of multiple Micstasys, but also of all other supported devices, even in mixed setups.

The software MIDI Remote also controls RME's ADI-6432, ADI-648, ADI-642, ADI-8 QS, the whole M-series and the MADI Bridge.

The following settings are not supported under MIDI, therefore can not be set using MIDI Remote:

- The order of the functions (Select key 7/8)
- Pro Tools MIDI compatibility On/Off (Setup menu)

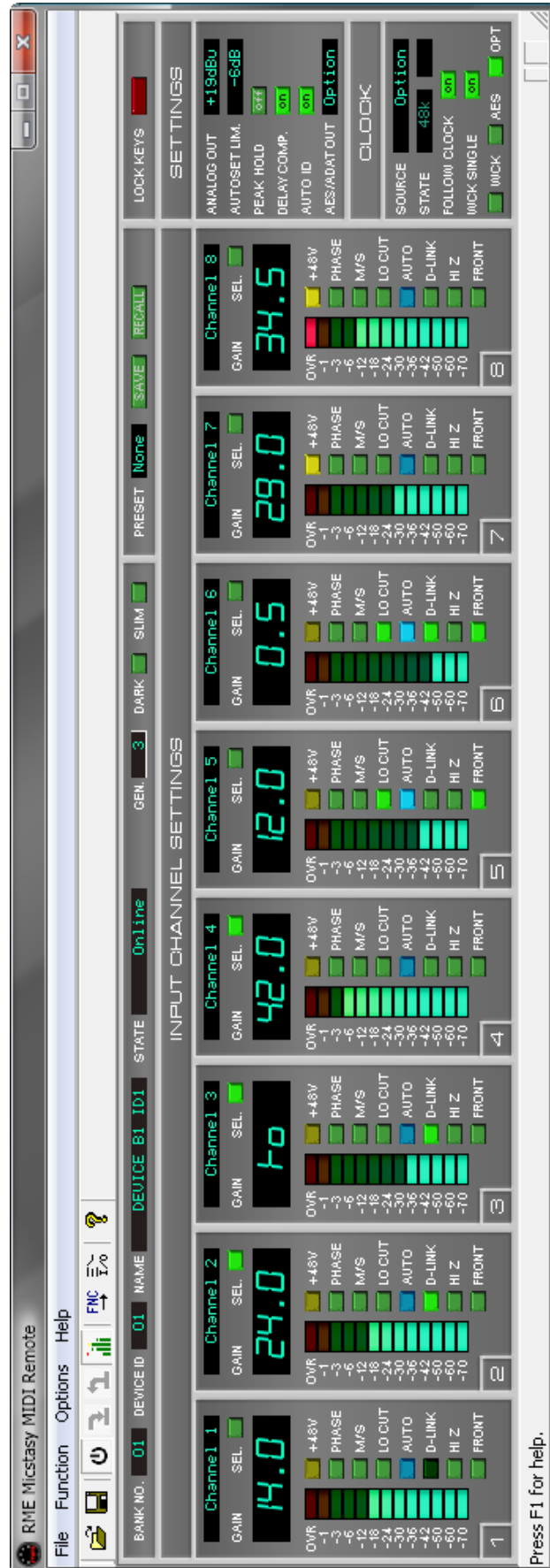

User's Guide



Micstasy

▶ Inputs and Outputs

13. Analog Inputs / Outputs

13.1 Mic / Line In Rear

The Micstasy has 8 balanced full range XLR inputs on the back panel. The electronic input stage is built in a servo balanced design which handles unbalanced and balanced signals correctly, automatically adjusting the level reference.



When using unbalanced cables be sure to connect pin 3 (-) to 1 (ground). Otherwise noise may occur, caused by the unconnected negative input of the balanced input.

The pin assignment follows international standards. With XLR, pin 2 is + or hot, pin 3 is – or cold, pin 1 is ground. Pin 1 is connected to the chassis directly at the socket (AES48).

The rear inputs of the Micstasy offer an adjustable amplification from -9 dB up to +76.5 dB. This equals a sensitivity of +30 dBu down to -56.5 dBu, referenced to full scale of the AD-converter. Changing the gain is usually done click-free, as the gain change is performed during the zero crossing of the audio signal, if possible.

The soft switching, hi-current phantom power (48 Volt) provides a professional handling of condenser microphones. The usage of a hi-end integrated circuit (PGA 2500) plus a fully symmetrical signal path guarantees outstanding sound quality, stunning low THD, and maximum Signal to Noise ratio in any gain setting.

Due to the Micstasy's flexibility, its signal to noise ratio is not easy to determine. The EIN value is constant across a very wide amplification range, typically 127 dBu at 150 Ohm input impedance. Even at a gain setting of 30, which corresponds to 0 dBFS at only -9 dBu, the EIN still reaches 122 dBu.

The Micstasy's 'overall' amplification from analog input to analog output depends on the analog output reference setting. The EIN is not affected by this setting, since the S/N ratio scales 1:1 with the output amplification.

The Micstasy also delivers excellent performance as a converter for line signals. At a reference level of +21 dBu for 0 dBFS (GAIN 00), S/N is 113 dBu unweighted (116 dBA). At +13 dBu for digital full scale, it is 110 dBu unweighted (113 dBA). Due to a very special circuitry the signal to noise ratio is completely independent from the source impedance. The front line input reaches the exact same values as the rear input, from +21 dBu down to 0 dBu (GAIN 21.5).

13.2 Instrument / Line In Front

Line

The Micstasy's front has 8 balanced 1/4" TRS inputs. The electronic input stage is built in a servo balanced design which handles unbalanced (mono jacks) and balanced (stereo jacks) correctly, automatically adjusting the level reference.



When using unbalanced cables with TRS jacks: be sure to connect the 'ring' contact of the TRS jack to ground. Otherwise noise may occur, caused by the unconnected negative input of the balanced input

Instrument

The main difference between a line and an instrument input is its input impedance. The function **HI Z** raises the input impedance from 5.6 kOhm to 470 kOhm.

The input Inst/Line operates fully servo-balanced even with Hi-Z activated.

The front inputs of the Micstasy offer an adjustable amplification from 0 dB up to +50 dB. This equals a sensitivity of +21 dBu down to -29 dBu, referenced to full scale of the AD-converter. Changing the gain is usually done click-free, as the gain change is performed during the zero crossing of the audio signal, if possible.

13.3 Line Out

The Micstasy has 8 balanced XLR outputs on the back panel.



The electronic output stage does not operate servo balanced! When connecting unbalanced equipment, make sure pin 3 of the XLR output is not connected. A connection to ground can cause a higher THD value (higher distortion)!

The button **ANALOG OUT** is used to define the analog reference level at the analog outputs. The reference level is reached at full scale of the AD-converters, thus matching the front panel level meter's level indication.

Reference	0 dBFS @	Analog Headroom
+24	+24 dBu	3 dB
+19	+19 dBu	8 dB
+13	+13 dBu	14 dB

The Micstasy delivers an undistorted maximum level of +27 dBu. The referencing is based on full scale of the AD-converters. 0 dBFS will be reached at +13, +19 or +24 dBu output level respectively.

The different output levels guarantee optimal conversion results, while still being compatible to any attached analog equipment. Note that ANALOG OUT has no influence on the technical specifications – distortion, frequency response and signal to noise ratio do not change, or rather exactly like the analog overall gain.

Set to +13 dBu and +19 dBu the Micstasy is fully compatible to all RME devices having +4 dBu and Lo Gain as input reference.

Reference	0 dBFS @	Headroom @ +4 dBu
Lo Gain	+19 dBu	15 dB
+4 dBu	+13 dBu	9 dB

Set to +24 dBu the Micstasy is compatible to SMPTE (+24 dBu @ 0 dBFS, +4 dBu with 20 dB of headroom).

14. Digital Outputs

14.1 AES/EBU

The four AES/EBU outputs are provided on the rear of the Micstasy via a 25 pin D-sub connector with Tascam pinout (also used by Digidesign). A digital breakout cable will provide 4 male (and 4 female) XLR connectors. Every output is transformer-balanced, ground-free and compatible to all devices with AES/EBU ports.

In normal operation the AES outputs carry the converted analog input signal. When using the I64 MADI Card and activating the option *oP* in the Setup menu *do*, the MADI input data is present at the output instead, see chapter 11.11.

Besides the audio data, digital signals in SPDIF or AES/EBU format contain a channel status coding, which is being used for transmitting further information. The output signal coding of the Micstasy has been implemented according to AES3-1992 Amendment 4:

- 32 kHz, 44.1 kHz, 48 kHz, 64 kHz, 88.2 kHz, 96 kHz, 176.4 kHz, 192 kHz according to the current sample rate
- Audio use
- No Copyright, Copy permitted
- Format Professional
- Category General, Generation not indicated
- 2-Channel, No Emphasis
- Aux bits audio use, 24 bit
- Origin: MICS

Connecting devices with coaxial SPDIF ports to the Micstasy's outputs is accomplished by simple cable adapters XLR/RCA. To achieve this, pins 2 and 3 of an XLR plug are being connected to the two contacts of a Phono/RCA plug. The ground shield of the cable is only connected to pin 1 of the XLR plug.

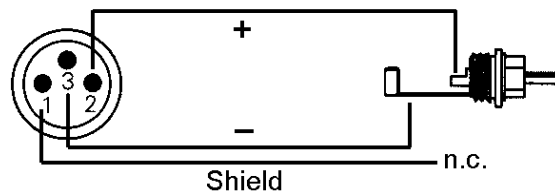

 *Note that most consumer HiFi equipment with phono SPDIF inputs will only accept signals with Channel Status 'Consumer'! In such cases the above adapter cable will not work.*

The Micstasy supports Single Wire only, in the range of 32 kHz up to 192 kHz: a total of 8 channels, 2 channels per AES wire. The effective sample frequency equals the clock on the AES wire. In case a conversion from/to Single, Double and Quad Wire is required, the RME ADI-192 DD, an 8-channel universal sample rate and format converter, is highly recommended.

Pinout of the D-sub connector, Outputs

Signal	Out 1/2+	Out 1/2-	Out 3/4+	Out 3/4-	Out 5/6+	Out 5/6-	Out 7/8+	Out 7/8-
D-Sub	18	6	4	17	15	3	1	14

GND is connected to pins 2, 5, 8, 11, 16, 19, 22, 25. Pin 13 is not connected.

AES/EBU Sync

The input AES 1 (channel 1/2) found on the D-sub connector can not be used for audio with the Micstasy, but as clock source. The input is transformer-balanced and ground-free. Thanks to a highly sensitive input stage, a SPDIF signal can also be fed by using a simple cable adapter phono/XLR (see above).

Pinout of the D-sub connector, Inputs

Signal	In 1/2+	In 1/2-	In 3/4+	In 3/4-	In 5/6+	In 5/6-	In 7/8+	In 7/8-
D-sub	24	12	10	23	21	9	7	20

GND is connected to pins 2, 5, 8, 11, 16, 19, 22, 25. Pin 13 is not connected.

14.2 ADAT Optical

The Micstasy provides two digital outputs in ADAT optical format. In normal operation these ports carry the converted analog input signal. When using the I64 MADI Card and activating the option *oP* in the Setup menu *do*, the MADI input data is present at the output instead, see chapter 11.11. In Single Speed mode both outputs carry the same audio data. With this it is possible to distribute the output signal to two devices (2 x ADAT splitter).

As the ADAT optical signal is physically specified up to 48 kHz only, the Micstasy automatically activates Sample Split mode (S/MUX) at 88.2 and 96 kHz, distributing the data of one channel to two output channels. The internal frequency stays at 44.1/48 kHz. Therefore the sample clock at the ADAT outputs is only half the frequency of the AES outputs. As interesting as this is – you don't need to think about it. 96 kHz capable ADAT hardware, like all current RME digital interfaces, re-combine the data automatically. The user (and the DAW software) does not see any split data, but just single channels at the expected double sample rate.

The ADAT outputs can be used in parallel to the AES outputs at up to 192 kHz, but in QS mode only channels 1 to 4 will be available.

The ADAT optical outputs of the Micstasy are fully compatible to all ADAT optical inputs. A usual TOSLINK cable is sufficient for connection.

ADAT Main

Interface for the first or only device receiving an ADAT signal from the Micstasy. Carries the channels 1 to 8. When sending a Double Speed signal, this port carries the channels 1 to 4. In Quad Speed mode this port carries channels 1 and 2.

ADAT AUX

In Single Speed mode carries a copy of the data at the Main output. When sending a Double Speed signal, this port carries the channels 5 to 8. In Quad Speed mode this port carries the channels 3 and 4.

14.3 I64 MADi Card

The I64 MADi Card provides the Micstasy with a 64-channel MADi input and output. Coaxial and optical output operate simultaneously and deliver the same data. The ID determines which MADi channels the Micstasy will use (see chapter 11.4, ID). The MADi outputs operate in parallel to the AES/EBU and ADAT outputs, provide the same audio data, and are configured with the same front panel controls.

The I64 MADi Card features an optical as well as a coaxial MADi input. The input is switched automatically, according to where a valid input signal is detected. Full redundancy is ensured by the automatic input switching, immediately changing to the other input in case of loss of the input signal.

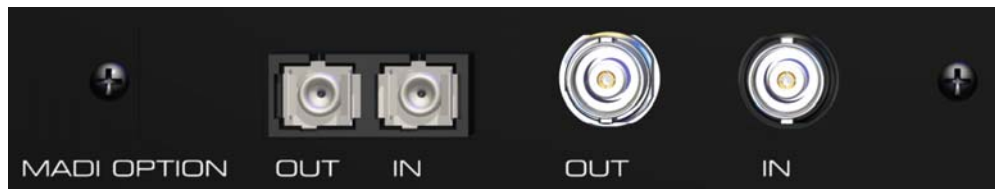

The MADi input will operate as an optional clock source (Clock section, OPTN) as well as a through input. Since each Micstasy uses only 8 channels, up to 56 channels can be passed through.

This technique is used to serially cascade several Micstasy. Incoming MADi data is passed through unchanged, only one block of eight channels is replaced, according to the Micstasy's ID. This allows up to 8 devices to be connected serially. All 64 combined channels are available at the last device's output. The ID determining the block of eight channels used by an individual device is determined automatically (Auto ID) or manually in the setup menu (ID):

- ID 01: channels 1-8
- ID 02: channels 9-16
- ID 03: channels 17-24
- ID 04: channels 25-32
- ID 05: channels 33-40
- ID 06: channels 41-48
- ID 07: channels 49-56
- ID 08: channels 57-64

The I64 MADi Card defaults to the 56-channel format at its outputs. As soon as a 64-channel format is detected at the inputs, or the ID 08 is used, the output switches to 64-channel format.

Note: The 96k frame mode is activated at the outputs automatically when the MADi input signal is 96k frame. A manual selection of the output format, and with this a converter functionality 48k/96k, is not available.

With an installed I64 MADi Card the Micstasy can be remote controlled via MADi. At the same time MIDI data are transmitted via MADi, see chapter 12.2.

When multiple devices are connected serially, the MADi I/O of each Micstasy causes a delay of 3 samples. Therefore at the MADi output of the last device, the data of all upstreamed devices are delayed. At Double Speed the delay rises to 6 samples per unit, at Quad Speed to 12 samples.

The problem of this offset is solved by the function *Delay Compensation*, see chapter 11.3. It delays the signals in a way that they are sample-synchronous in multi-device operation. The diagram on the next page shows a serial setup with HDSP MADi card, three Micstasy and activated Delay Compensation.



Delay Compensation has to be manually activated in each unit!

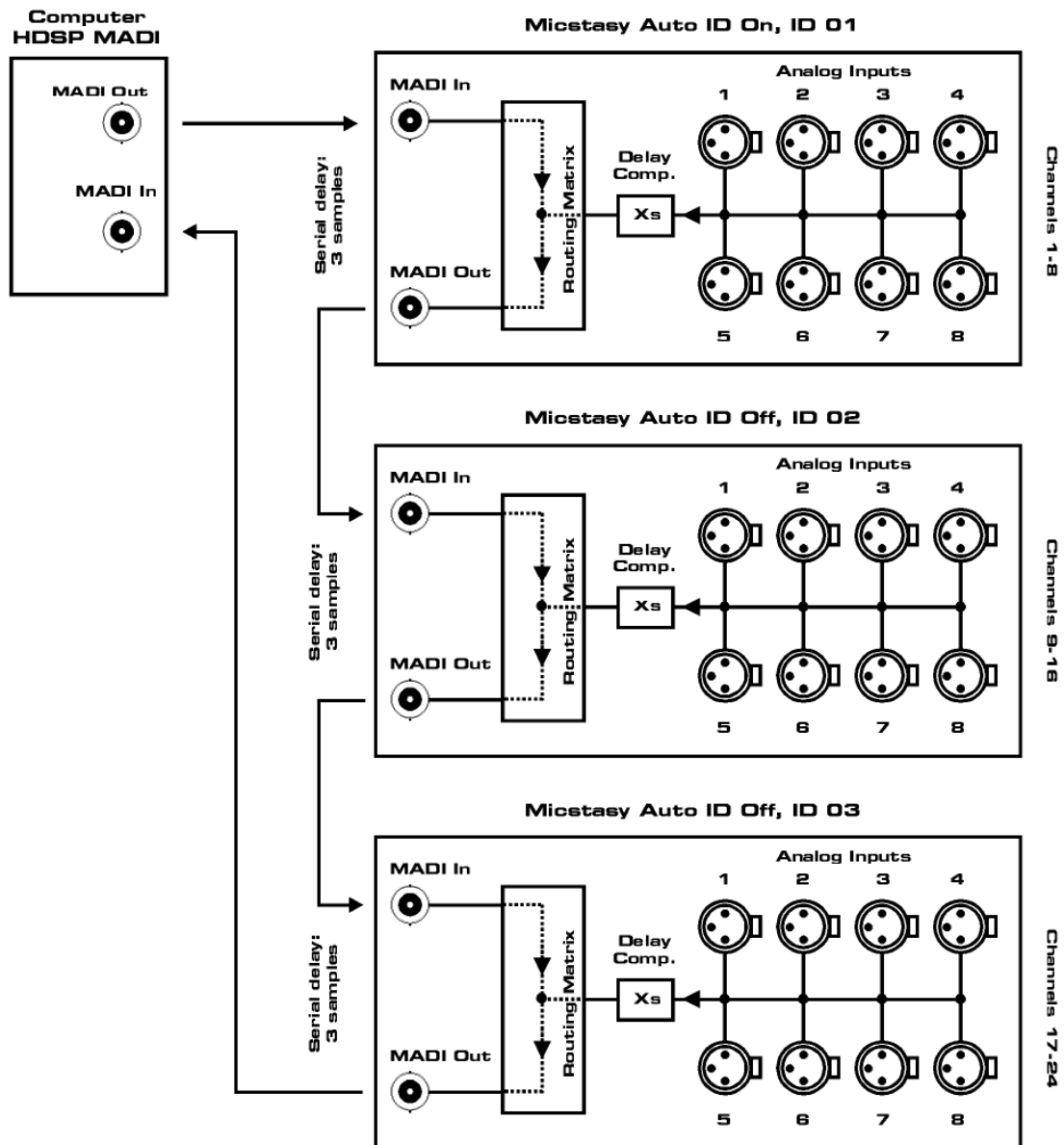

14.4 Differences serial MADI with I64 MADI Card and ADI-642

I64 MADI Card: Activate Auto ID in the first unit (ID of the master can be changed). All following units become Slave, get a consecutive ID, and with this the according channel routing. If desired, Delay Compensation has to be manually activated in each unit.

ADI-642: Activate ADC (Auto Delay Compensation) in the first unit (ID of the master is always 1). All following units become Slave, and compensate the respective delay automatically. The routing is done according to the setting of the matrix. If *Auto* (Auto Channel Assignment) is activated in the first unit too, all following units get a consecutive ID, and with this the according channel routing.

Mixed setups: Auto ID and Auto are compatible. In contrast (A)DC is automatic only with the 642. The Micstasys require to activate Delay Compensation manually in each unit.

15. Word Clock

15.1 Word Clock Input and Output

SteadyClock guarantees an excellent performance in all clock modes. Its highly efficient jitter suppression refreshes and cleans up any clock signal, and provides it as reference clock at the BNC output (see section 17.10).

Input

The Micstasy's transformer isolated word clock input is active when WCK is chosen in the clock section. The signal at the BNC input can be Single, Double or Quad Speed, the Micstasy automatically adapts to it. As soon as a valid signal is detected, the WCK LED is constantly lit, otherwise it is flashing.

Thanks to RME's *Signal Adaptation Circuit*, the word clock input still works correctly even with heavily mis-shaped, dc-prone, too small or overshoot-prone signals. Thanks to automatic signal centering, 300 mV (0.3V) input level is sufficient in principle. An additional hysteresis reduces sensitivity to 1.0 V, so that over- and undershoots and high frequency disturbances don't cause a wrong trigger.

The word clock input is shipped as high impedance type (not terminated). A push switch allows to activate internal termination (75 Ohms). The switch is found on the back beside the BNC socket. Use a small pencil or similar and carefully push the blue switch so that it snaps into its lock position and the yellow LED lights up. Another push will release it again and de-activate the termination.



Output

The Micstasy's word clock output is constantly active, providing the current sample frequency as word clock signal. In master mode, the word clock will be fixed to 44.1 kHz or 48 kHz (DS x 2, QS x 4). In any other case the sample rate is identical to the one present at the currently chosen clock input. When the current word clock source fails, the last valid sample rate will be held automatically.

Selecting the option *Si* in the Setup menu *Co* causes the word clock output to always stay within the range of 32 kHz to 48 kHz. So at 96 kHz and 192 kHz sample rate, the output word clock is 48 kHz.

The word clock signal received by the Micstasy can be distributed to other devices by using the word clock output. With this the usual T-adaptor can be avoided, and the Micstasy operates as *Signal Refresher*. This kind of operation is highly recommended, because

- Input and output are phase-locked and in phase (0°) to each other
- *SteadyClock* removes nearly all jitter from the input signal
- the exceptional input (1 Vpp sensitivity instead of the usual 2.5 Vpp, dc cut, *Signal Adaptation Circuit*) plus *SteadyClock* guarantee a secure function also with most critical word clock signals.

Thanks to a low impedance, but short circuit proof output, the Micstasy delivers 4 Vpp to 75 Ohms. For wrong termination with 2 x 75 Ohms (37.5 Ohms), there are still 3.3 Vpp at the output.

15.2 Operation and Technical Background

In the analog domain one can connect any device to another device, a synchronization is not necessary. Digital audio is different. It uses a clock, the sample frequency. The signal can only be processed and transmitted when all participating devices share the same clock. If not, the signal will suffer from wrong samples, distortion, crackle sounds and drop outs.

AES/EBU, SPDIF, ADAT and MADI are self-clocking, an additional word clock connection in principle isn't necessary. But when using more than one device simultaneously problems are likely to happen. For example any self-clocking will not work in a loop cabling, when there is no 'master' (main clock) inside the loop. Additionally the clock of all participating devices has to be synchronous. This is often impossible with devices limited to playback, for example CD players, as these have no SPDIF input, thus can't use the self clocking technique as clock reference.

In a digital studio synchronisation is maintained by connecting all devices to a central sync source. For example the mixing desk works as master and sends a reference signal, the word clock, to all other devices. Of course this will only work as long as all other devices are equipped with a word clock or sync input, thus being able to work as slave (some professional CD players indeed have a word clock input). Then all devices get the same clock and will work in every possible combination with each other.



Remember that a digital system can only have one master! If the Micstasy uses its internal clock, all other devices must be set to 'Slave' mode.

But word clock is not only the 'great problem solver', it also has some disadvantages. The word clock is based on a fraction of the really needed clock. For example SPDIF: 44.1 kHz word clock (a simple square wave signal) has to be multiplied by 256 inside the device using a special PLL (to about 11.2 MHz). This signal then replaces the one from the quartz crystal. Big disadvantage: because of the high multiplication factor the reconstructed clock will have great deviations called jitter. The jitter of a word clock is much higher as when using a quartz based clock.

The end of these problems should have been the so called Superclock, which uses 256 times the word clock frequency. This equals the internal quartz frequency, so no PLL for multiplying is needed and the clock can be used directly. But reality was different, the Superclock proved to be much more critical than word clock. A square wave signal of 11 MHz distributed to several devices - this simply means to fight with high frequency technology. Reflections, cable quality, capacitive loads - at 44.1 kHz these factors may be ignored, at 11 MHz they are the end of the clock network. Additionally it was found that a PLL not only generates jitter, but also rejects disturbances. The slow PLL works like a filter for induced and modulated frequencies above several kHz. As the Superclock is used without any filtering such a kind of jitter and noise suppression is missing.

The actual end of these problems is offered by the **SteadyClock** technology of the Micstasy. Combining the advantages of modern and fastest digital technology with analog filter techniques, re-gaining a low jitter clock signal of 22 MHz from a slow word clock of 44.1 kHz is no problem anymore. Additionally, jitter on the input signal is highly rejected, so that even in real world usage the re-gained clock signal is of highest quality.

15.3 Cabling and Termination

Word clock signals are usually distributed in the form of a network, split with BNC T-adapters and terminated with resistors. We recommend using off-the-shelf BNC cables to connect all devices, as this type of cable is used for most computer networks. Actually you will find all the necessary components (T-adapters, terminators, cables) in most electronics and computer stores. The latter usually carries 50 Ohm components. The 75 Ohm components used for word clock are part of video technology (RG59).

Ideally, the word clock signal is a 5 Volt square wave with the frequency of the sample rate, of which the harmonics go up to far above 500 kHz. To avoid voltage loss and reflections, both the cable itself and the terminating resistor at the end of the chain should have an impedance of 75 Ohm. If the voltage is too low, synchronization will fail. High frequency reflection effects can cause both jitter and sync failure.

Unfortunately there are still many devices on the market, even newer digital mixing consoles, which are supplied with a word clock output that can only be called unsatisfactory. If the output breaks down to 3 Volts when terminating with 75 Ohms, you have to take into account that a device, of which the input only works from 2.8 Volts and above, does not function correctly already after 3 meter cable length. So it is not astonishing that because of the higher voltage, word clock networks are in some cases more stable and reliable if cables are not terminated at all.

Ideally all outputs of word clock delivering devices are designed as low impedance types, but all word clock inputs as high impedance types, in order to not weaken the signal on the chain. But there are also negative examples, when the 75 Ohms are built into the device and cannot be switched off. In this case the network load is often 2 x 75 Ohms, and the user is forced to buy a special word clock distributor. Note that such a device is generally recommended for larger studios.

The Micstasy's word clock input can be high-impedance or terminated internally, ensuring maximum flexibility. If termination is necessary (e.g. because the Micstasy is the last device in the chain), push the switch at the back (see chapter 15.1).

In case the Micstasy resides within a chain of devices receiving word clock, plug a T-adapter into its BNC input jack, and the cable supplying the word clock signal to one end of the adapter. Connect the free end to the next device in the chain via a further BNC cable. The last device in the chain should be terminated using another T-adapter and a 75 Ohm resistor (available as short BNC plug). Of course devices with internal termination do not need T-adapter and terminator plug.



Due to the outstanding SteadyClock technology of the Micstasy, we recommend to not pass the input signal via T-adapter, but to use the Micstasy's word clock output instead. Thanks to SteadyClock, the input signal will both be freed from jitter and - in case of loss or drop out - be held at the last valid frequency.

16. MIDI

The Micstasy has a standard MIDI input and output, a 5-pin DIN jack each. The MIDI I/O is used for:

- remote control of the Micstasy, see chapter 12.1
- transmission of MIDI data and remote control commands over MADI, in case the optional I64 MADI Card has been fitted, see chapter 12.2.



User's Guide



Micstasy

▶ **Technical Reference**

17. Technical Specifications

17.1 Analog

Microphone/Line 1-8, rear

- Input: XLR, electronically balanced
- Input impedance: 2 kOhm
- Frequency response -0.1 dB: 20 Hz – 100 kHz
- Frequency response -0.3 dB: 10 Hz – 150 kHz
- THD @ 30 dB Gain: < -110 dB, < 0.0003 %
- THD+N @ 30 dB Gain: < -100 dB, < 0.001 %
- Channel separation: > 120 dB
- CMRR 50 Hz: > 60 dB
- CMRR 200 Hz – 20 kHz: > 70 dB

- EIN @ 30 dB Gain @ 150 Ohm: 122.0 dBu
- EIN @ 40 dB Gain @ 150 Ohm: 126.1 dBu
- EIN @ 50/60/70 dB Gain @ 150 Ohm: 127.2 dBu

- EIN @ 30 dB Gain @ 0 Ohm: 122.5 dBu
- EIN @ 40 dB Gain @ 0 Ohm: 128.8 dBu
- EIN @ 50/60/70 dB Gain @ 0 Ohm: 130.3 dBu

- Gain range: -9 dB up to +76.5 dB
- Maximum input level, Gain -9 dB: +30 dBu
- Maximum input level, Gain 76.5 dB: -56.5 dBu

Inst/Line In 1-8, front

- Input: 6.3 mm TRS jack, electronically balanced
- Input impedance: 5.6 kOhm unbalanced 11.2 kOhm balanced
- Input impedance Hi-Z: 470 kOhm
- Frequency response -0.1 dB: 20 Hz – 100 kHz
- Frequency response -0.3 dB: 10 Hz – 150 kHz
- THD @ 30 dB Gain: < -110 dB, < 0.0003 %
- THD+N @ 30 dB Gain: < -100 dB, < 0.001 %
- Channel separation: > 120 dB

- Signal to Noise ratio (SNR) @ Gain 0 dB: 112.4 dB RMS unweighted, 116 dBA

- Gain range: 0 up to +50 dB
- Maximum input level, Gain 0 dB: +21 dBu
- Maximum input level, Gain 50 dB: -29 dBu

Line Out 1-8, rear

- Maximum output level: +27 dBu
- Output: XLR, balanced
- Output impedance: 150 Ohm
- Output level switchable +13 dBu, +19 dBu, +24 dBu

AD-conversion

- Resolution: 24 Bit
- Signal to Noise ratio (SNR) @ +30 dBu: 115.0 dB RMS unweighted, 118 dBA
- Signal to Noise ratio (SNR) @ +21 dBu: 112.4 dB RMS unweighted, 116 dBA
- Signal to Noise ratio (SNR) @ +13 dBu: 110 dB RMS unweighted, 113 dBA

- Frequency response @ 44.1 kHz, -0.5 dB: 5 Hz – 20.6 kHz
- Frequency response @ 96 kHz, -0.5 dB: 5 Hz – 45.3 kHz
- Frequency response @ 192 kHz, -1 dB: 5 Hz - 70 kHz
- THD+N: < -110 dB, < 0.0003 %
- Channel separation: > 110 dB

17.2 Digital Inputs

AES/EBU

- 1 x 25-pin D-sub, transformer-balanced, galvanically isolated, according to AES3-1992
- High-sensitivity input stage (< 0.3 Vpp)
- SPDIF compatible (IEC 60958)
- Accepts Consumer and Professional format
- Lock Range: 27 kHz – 200 kHz
- Jitter when synced to input signal: < 1 ns
- Jitter suppression: > 30 dB (2.4 kHz)

Word Clock

- BNC, not terminated (10 kOhm)
- Switch for internal termination 75 Ohm
- Automatic Double/Quad Speed detection and internal conversion to Single Speed
- SteadyClock guarantees super low jitter synchronization even in varispeed operation
- Transformer coupled, galvanically isolated input
- Not affected by DC-offsets within the network
- Signal Adaptation Circuit: signal refresh through auto-center and hysteresis
- Overvoltage protection
- Level range: 1.0 Vpp – 5.6 Vpp
- Lock Range: 27 kHz – 200 kHz
- Jitter when synced to input signal: < 1 ns
- Jitter suppression: > 30 dB (2.4 kHz)

I64 MADI Card

- Coaxial via BNC, 75 Ohm, according to AES10-1991
- High-sensitivity input stage (< 0.2 Vpp)
- Optical via FDDI duplex SC connector
- 62.5/125 and 50/125 compatible
- Accepts 56 channel and 64 channel mode, and 96k frame
- Single Wire: up to 64 channels 24 bit 48 kHz
- Double Wire / 96k frame: up to 32 channels 24 bit 96 kHz
- Quad Wire: up to 16 channels 24 bit 192 kHz
- Lock range: 28 kHz – 54 kHz
- Jitter when synced to input signal: < 1 ns
- Jitter suppression: > 30 dB (2.4 kHz)

17.3 Digital Outputs

AES/EBU

- 4 x, transformer-balanced, galvanically isolated, according to AES3-1992
- Output voltage Professional 4.5 Vpp
- Format Professional according to AES3-1992 Amendment 4
- Single Wire: 4 x 2 channels 24 bit, up to 192 kHz

ADAT

- 2 x TOSLINK
- Standard: 8 channels 24 bit, up to 48 kHz
- S/MUX: 16 channels 24 bit / 48 kHz, equalling 8 channels 24 bit 96 kHz
- S/MUX4: 16 channels 24 bit / 48 kHz, equalling 4 channels 24 bit 192 kHz

Word Clock

- BNC
- Max. output voltage: 5 Vpp
- Output voltage @ 75 Ohm: 4.0 Vpp
- Impedance: 10 Ohm
- Frequency range: 27 kHz – 200 kHz

I64 MADI Card

- Coaxial via BNC, 75 Ohm, according to AES10-1991
- Output voltage 600 mVpp
- Cable length coaxial: up to 100 m
- Optical via FDDI duplex SC connector
- 62.5/125 and 50/125 compatible
- Cable length optical: more than 500 m
- Generates 56 channel and 64 channel mode, and 96k frame
- Single Wire: up to 64 channels 24 bit 48 kHz
- Double Wire / 96k frame: up to 32 channels 24 bit 96 kHz
- Quad Wire: up to 16 channels 24 bit 192 kHz

17.4 Digital

- Clocks: Internal, AES In, Wordclock In, Option In
- Low Jitter Design: < 1 ns in PLL mode, all inputs
- Internal clock: 800 ps Jitter, Random Spread Spectrum
- Jitter suppression of external clocks: > 30 dB (2.4 kHz)
- Effective clock jitter influence on AD-conversion: near zero
- PLL ensures zero dropout, even at more than 100 ns jitter
- Supported sample rates: 28 kHz up to 200 kHz

17.5 MIDI

- 16 channels MIDI
- 5-pin DIN jacks
- Optocoupled, ground-free input

I64 MADI Card

- Invisible transmission via User bit of channel 56 (48k frame)

17.6 General

- Power supply: Internal switching PSU, 100 - 240 V AC, 60 Watts
- Typical power consumption: 24 Watts
- Maximum power consumption: < 40 Watts
- Dimensions including rack ears (WxHxD): 483 x 88 x 242 mm (19" x 3.46" x 9.5")
- Dimensions without rack ears/handles (WxHxD): 436 x 88 x 235 mm (17.2" x 3.46" x 9.3")
- Weight: 3 kg (6.6 lbs)
- Temperature range: +5° up to +50° Celsius (41° F up to 122°F)
- Relative humidity: < 75%, non condensing

17.7 Firmware

The Micstasy is internally based on programmable logic. By re-programming of a little component called Flash-PROM, both function and behaviour of the unit can be changed at any time.

At the time of writing this manual, the unit is shipped with firmware 2.0. The firmware version is displayed after power on for about one second on the Gain displays of the Micstasy.

Firmware 1.2: Initial release

Firmware 1.6: All relays are activated upon power-on to avoid contact problems. State of the Setup menu is saved temporarily.

Firmware 2.0 includes new functions (MADI In to ADAT/AES Out, remote support for Yamaha PM5D, word clock out switchable to Single Speed).

Firmware 2.1 includes the new functions *Display Auto Dark* and *Test Oscillator*.

Firmware Updates: The firmware itself is free of charge. However, the costs of shipment and flashing the unit in the factory have to be paid by the customer. Please contact the RME support or your local dealer.

The I64 MADI Card has its own firmware. Micstasy M with firmware below 1.6 have a I64 MADI Card that can not be used with varipitch. I64 MADI Cards with the latest firmware have a sticker with the firmware version date code on them. The latest one is 20081220, identical to 20090113 (Micstasy with firmware 2.1 have these already inside). The firmware of the I64 MADI Card can be updated in the factory. Please contact the RME support or your local dealer.

17.8 MADI User Bit Chart

- RS-232: channels 1 to 9 (through mode active in the I64 MADI Card)
- ADC: channel 19
- MIDI: channel 56 (48k) / 28 (96k)

17.9 Connector Pinouts

The 25 pin D-sub connector provides four AES inputs and outputs. The pinout uses the widely spread Tascam scheme, which is also used by Digidesign.

Tascam / Digidesign:

Signal	In 1/2+	In 1/2-	In 3/4+	In 3/4-	In 5/6+	In 5/6-	In 7/8+	In 7/8-
D-Sub	24	12	10	23	21	9	7	20

Signal	Out 1/2+	Out 1/2-	Out 3/4+	Out 3/4-	Out 5/6+	Out 5/6-	Out 7/8+	Out 7/8-
D-Sub	18	6	4	17	15	3	1	14

GND is connected to pins 2, 5, 8, 11, 16, 19, 22, 25. Pin 13 is not connected.

The Yamaha pinout is quite popular as well. When building a D-sub to D-sub adapter or connection cable, please make sure that the connectors are clearly labelled with *Tascam* and *Yamaha*. The cable can only be used when the Tascam side is connected to a Tascam connector, and the Yamaha side is connected to a Yamaha connector.

Yamaha:

Signal	In 1/2+	In 1/2-	In 3/4+	In 3/4-	In 5/6+	In 5/6-	In 7/8+	In 7/8-
D-Sub	1	14	2	15	3	16	4	17

Signal	Out 1/2+	Out 1/2-	Out 3/4+	Out 3/4-	Out 5/6+	Out 5/6-	Out 7/8+	Out 7/8-
D-Sub	5	18	6	19	7	20	8	21

GND is connected to pins 9, 10, 11, 12, 13, 22, 23, 24, 25.

The same is true for a direct adapter cable Tascam D-sub to Euphonix D-sub.

Euphonix:

Signal	In 1/2+	In 1/2-	In 3/4+	In 3/4-	In 5/6+	In 5/6-	In 7/8+	In 7/8-
D-Sub	15	2	4	16	18	5	7	19

Signal	Out 1/2+	Out 1/2-	Out 3/4+	Out 3/4-	Out 5/6+	Out 5/6-	Out 7/8+	Out 7/8-
D-Sub	21	8	10	22	24	11	13	25

GND is connected to pins 3, 6, 9, 12, 14, 17, 20, 23. Pin 1 is not connected.

XLR sockets analog input and output

The XLR connectors of the analog inputs and outputs are wired according to international standards:

1 = GND (shield)
2 = + (hot)
3 = - (cold)

The servo balanced input and output circuitry allows to use unbalanced connections with no loss in level. For this to work, pins 3 (-) and 1 (GND) have to be connected inside the XLR connector.

The output circuitry does not operate in a servo-balanced way. When connecting unbalanced devices make sure that pin 3 of the XLR output stays unconnected.

TRS jacks analog input

The stereo ¼" TRS jacks of the analog inputs are wired according to international standards:

Tip = + (hot)
Ring = - (cold)
Sleeve = GND

The servo balanced input circuitry allows to use monaural TS jacks (unbalanced) with no loss in level. This is the same as when using a TRS-jack with ring connected to ground.

18. Technical Background

18.1 Terminology

Single Speed

Sample rate range originally used in Digital Audio. Typical applications are 32 kHz (digital radio broadcast), 44.1 kHz (CD), and 48 kHz (DAT).

Double Speed

Doubles the original sample rate range, in order to achieve higher audio quality and improved audio processing. 64 kHz is practically never used, 88.2 kHz is quite rare in spite of certain advantages. 96 kHz is a common format. Sometimes called **Double Fast**.

Quad Speed

Controversially discussed way of ensuring hi-end audio quality and processing by quadrupling the sample frequency. 128 kHz is non-existent, 176.4 kHz is rare, if at all then 192 kHz is used, e.g. for DVD Audio.

Single Wire

Standard audio data transfer, where the audio signal's sample rate is equal to the rate of the digital signal. Used from 32 to 192 kHz. Sometimes called **Single Wide**.

Double Wire

Before 1998 there were no receiver/transmitter circuits available that could receive or transmit more than 48 kHz. Higher sample rates were transferred by splitting odd and even bits across the L/R channels of a single AES connection. This provides for twice the data rate, and hence twice the sample rate. A stereo signal subsequently requires two AES/EBU ports.

The Double Wire method is an industry standard today, however it has a number of different names, like **Dual AES**, **Double Wide**, **Dual Line** and **Wide Wire**. The AES3 specification uses the uncommon term *Single channel double sampling frequency mode*. When used with the ADAT format, the term S/MUX is commonly used.

Double Wire not only works with Single Speed signals, but also with Double Speed. As an example, Pro Tools HD, whose AES receiver/transmitter only work up to 96 kHz, uses Double Wire to transmit 192 kHz. Four channels of 96 kHz turn into two channels of 192 kHz.

Quad Wire

Similar to Double Wire, with samples of one channel spread across four channels. This way single speed devices can transmit up to 192 kHz, but need two AES/EBU ports to transmit one channel. Also called **Quad AES**.

S/MUX

Since the ADAT hardware interface is limited to Single Speed, the Double Wire method is used for sample rates up to 96 kHz, but usually referred to as S/MUX (Sample Multiplexing). An ADAT port supports four channels this way.

S/MUX4

The Quad Wire method allows to transmit two channels at up to 192 kHz via ADAT. The method is referred to as S/MUX4.

Note: All conversions of the described methods are lossless. The existing samples are just spread or re-united between the channels.

18.2 Lock and SyncCheck

Digital signals consist of a carrier and the data. If a digital signal is applied to an input, the receiver has to synchronize to the carrier clock in order to read the data correctly. To achieve this, the receiver uses a PLL (Phase Locked Loop). As soon as the receiver meets the exact frequency of the incoming signal, it is locked. This **Lock** state remains even with small changes of the frequency, because the PLL tracks the receiver's frequency.

If an AES or MADI signal is applied to the Micstasy, the corresponding LED starts flashing. The unit indicates LOCK, i. e. a valid input signal (in case the signal is in sync, the LED is constantly lit, see below).

Unfortunately, LOCK does not necessarily mean that the received signal is correct with respect to the clock which processes the read out of the embedded data. Example [1]: The Micstasy is set to 44.1 kHz internal clock (clock mode master), and a mixing desk with MADI output is connected to the I64 MADI input. The OPTN LED will start flashing immediately, because the mixing desk's sample rate is generated internally, and thus slightly higher or lower than the Micstasy's internal sample rate. Result: When reading out the data, there will frequently be read errors that cause clicks and drop outs.

Also when using multiple inputs, a simple LOCK is not sufficient. The above described problem can be solved elegantly by setting the Micstasy from internal clock to MADI (its internal clock will then be the clock delivered by the mixing desk). But in case another asynchronous device is connected, there will again be a slight difference in the sample rate, and therefore clicks and drop outs.

In order to display those problems optically at the device, the Micstasy includes **SyncCheck**. It checks all clocks used for *synchronicity*. If they are not synchronous to each other (i. e. absolutely identical), the LED of the asynchronous input flashes. In case they are synchronous the LED stays dark, only the LED of the current clock source will be lit (constantly). In example 1 it would have been obvious that the OPTN LED starts flashing after connecting the mixing desk.

In practice, SyncCheck allows for a quick overview of the correct configuration of all digital devices. This way one of the most difficult and error-prone topics of the digital studio world finally becomes easy to handle.

18.3 Level References and Gain

The analog output levels of the Micstasy are designed to maintain a problem-free operation with most other devices. The headroom of the Micstasy reaches 9 to 20 dB, depending on the reference level.

Reference	Micstasy	0 dBFS @	Headroom
-	+24	+24 dBu	20 dB
Lo Gain	+19	+19 dBu	15 dB
+4 dBu	+13	+13 dBu	9 dB

With +13 selected, the according headroom of 9 dB meets the latest EBU recommendations for Broadcast usage. +19 is best suited for professional users who prefer to work balanced and at high levels. +19 provides 15 dB headroom at +4 dBu nominal level. Set to +24 the Micstasy is compatible to SMPTE (+24 dBu @ 0 dBFS, +4 dBu with 20 dB of headroom).

The above levels are also found in our ADI-8 series of AD/DA converters, the Multiface, Fireface, and even in our Mic-Preamps QuadMic and OctaMic. Therefore all RME devices are fully compatible to each other.

The definition of gain in a mic preamp proves to be difficult. While many devices claim a gain range from +10 dB up to +60 dB, the real gain often is somewhat different. The most simple way to define it is to compare analog input level to analog output level. Unfortunately the flexibility of the Micstasy (3 different analog reference levels) changes the 'overall' gain already by up to 11 dB.

And what about devices that don't have an analog output at all? If the mic preamp is connected directly to an AD-converter, there is no reference for measuring amplification. Often the scale of the microphone stage of an analog device is simply copied to the digital one. But since every preamp has a different adaptation to the AD-converter, all mic preamps end up having a different sensitivity - in spite of nominally identical gain settings.

Even the Micstasy can not completely solve this problem. To begin with, the analog levels match the above mentioned professional studio levels, in order to ensure the best possible compatibility between the AD-conversion and the analog outputs. The triple reference level further improves compatibility, but also causes the displayed gain level not to be accurate – it could only be accurate at one of the three settings.

We decided upon +19 dBu, but – after a further market survey – made another compromise. The displayed gain value refers to an input level of +21 dBu, for compatibility with other popular high-quality mic preamps. With this, their gain settings can now be simply transferred 1:1 to the Micstasy. In practice, what this means is as follows:

- At +21 dBu input level, a gain setting of 00 and +19 as analog output reference, the analog output level is +19 dBu. So the overall gain has an offset of -2 dB compared to the display.
- In this case the AD-converter reaches full scale (0 dBFS). Hence, the relation between the AD-converter and the analog output level reference is correct.
- With an input level of +19 dBu, the Micstasy must be set to a gain of +2 dB to produce an output level of +19 dBu, and to reach full scale at the converter stage.

When +13 is selected, the deviation will be -8 dB, while at +24 it is +3 dB.

BTW, taking into account the analog output reference of +24, the Micstasy even features a gain range of 90 dB.

18.4 Latency and Monitoring

The term **Zero Latency Monitoring** has been introduced by RME in 1998 for the DIGI96 series and describes the ability to pass-through the computer's input signal at the interface directly to the output. Since then, the idea behind has become one of the most important features of modern hard disk recording. In the year 2000, RME published two ground-breaking Tech Infos on the topics *Low Latency Background*, which are still up-to-date: *Monitoring, ZLM and ASIO*, and *Buffer and Latency Jitter*, found on the RME website.

How much Zero is Zero?

From a technical view there is no zero. Even the analog pass-through is subject to phase errors, equalling a delay between input and output. However, delays below certain values can subjectively be claimed to be a zero-latency. This applies to analog routing and mixing, and in our opinion also to RME's Zero Latency Monitoring. RME's digital receiver's buffer and the output via the transmitter cause a typical delay of 3 samples. At 44.1 kHz this equals about 68 μ s (0.000068 s), at 192 kHz only 15 μ s.

Oversampling

While the delays of digital interfaces can be disregarded altogether, the analog inputs and outputs do cause a significant delay. Modern converter chips operate with 64 or 128 times oversampling plus digital filtering, in order to move the error-prone analog filters away from the audible frequency range as far as possible. This typically generates a delay of about 40 samples, equalling one millisecond. A playback and re-record of the same signal via DA and AD (loop-back) then causes an offset of the newly recorded track of about 2 ms.

Low Latency!

The Micstasy uses a high-class AD-converter from Cirrus Logic, offering exceptional Signal to Noise and distortion figures. But the biggest difference to all other ADCs out there is its innovative digital filter, achieving for the first time a delay of only 12 samples in Single Speed, 9 samples in Double Speed, and 5 (!) samples in Quad Speed. The exact delays caused by the AD-conversion of the Micstasy are:

Sample frequency kHz	44.1	48	88.2	96	176.4	192
AD (12 x 1/fs) ms	0.27	0.25				
AD (9 x 1/fs) ms			0.1	0.09		
AD (5 x 1/fs) ms					0.028	0.026

These values are less than a quarter of those available from even much more expensive devices. They represent an important step in further reducing the latency in the computer-based recording studio. At DS and QS the added latency can simply be ignored. And with the ADI-8 QS, a matching DA-converter with only 5 up to 10 samples delay is ready to turn 'analog digital monitoring' into real analog-style monitoring.

18.5 DS - Double Speed

When activating the *Double Speed* mode the Micstasy operates at double sample rate. The internal clock 44.1 kHz turns to 88.2 kHz, 48 kHz to 96 kHz. The internal resolution is still 24 bit.

Sample rates above 48 kHz were not always taken for granted, and are still not widely used because of the CD format (44.1 kHz) dominating everything. Before 1998 there were no receiver/transmitter circuits available that could receive or transmit more than 48 kHz. Therefore a work-around was used: instead of two channels, one AES line only carries one channel, whose odd and even samples are being distributed to the former left and right channels. By this, you get the double amount of data, i. e. also double sample rate. Of course in order to transmit a stereo signal two AES/EBU ports are necessary then.

This transmission mode is called *Double Wire* in the professional studio world, and is also known as *S/MUX (Sample Multiplexing)* in connection with the ADAT format.

Not before February 1998, Crystal shipped the first 'single wire' receiver/transmitters that could also work with double sample rate. It was then possible to transmit two channels of 96 kHz data via one AES/EBU port.

But *Double Wire* is still far from being dead. On one hand, there are still many devices which can't handle more than 48 kHz, e. g. digital tape recorders. But also other common interfaces like ADAT or TDIF are still using this technique.

Because the ADAT interface does not allow for sampling frequencies above 48 kHz (a limitation of the interface hardware), the Micstasy automatically uses *Sample Multiplexing* in DS mode. One channel's data is distributed to two channels according to the following table:

Original	1	2	3	4	5	6	7	8
DS Signal	1/2	3/4	5/6	7/8	1/2	3/4	5/6	7/8
Port	1	1	1	1	2	2	2	2

As the transmission of double rate signals is done at standard sample rate (Single Speed), the ADAT outputs still deliver 44.1 kHz or 48 kHz.

18.6 QS – Quad Speed

Due to the small number of available devices that use sample rates up to 192 kHz, but even more due to a missing real world application (CD...), Quad Speed has had no broad success so far. An implementation of the ADAT format as double S/MUX (S/MUX4) results in only two channels per optical output. Therefore in Quad Speed mode the Micstasy is limited to 4 channels at the ADAT outputs.

The AES outputs provide 192 kHz as Single Wire only.

18.7 AES/EBU - SPDIF

The most important electrical properties of 'AES' and 'SPDIF' can be seen in the table below. AES/EBU is the professional balanced connection using XLR plugs. The standard is being set by the *Audio Engineering Society* based on the AES3-1992. For the 'home user', SONY and Philips have omitted the balanced connection and use either Phono plugs or optical cables (TOSLINK). The format called S/P-DIF (SONY/Philips Digital Interface) is described by IEC 60958.

Type	AES3-1992	IEC 60958
Connection	XLR	RCA / Optical
Mode	Balanced	Unbalanced
Impedance	110 Ohm	75 Ohm
Level	0.2 V up to 5 Vpp	0.2 V up to 0.5 Vpp
Clock accuracy	not specified	I: ± 50 ppm II: 0.1% III: Variable Pitch
Jitter	< 0.025 UI (4.4 ns @ 44.1 kHz)	not specified

Besides the electrical differences, both formats also have a slightly different setup. The two formats are compatible in principle, because the audio information is stored in the same place in the data stream. However, there are blocks of additional information, which are different for both standards. In the table, the meaning of the first byte (#0) is shown for both formats. The first bit already determines whether the following bits should be read as Professional or Consumer information.

Byte	Mode	Bit 0	1	2	3	4	5	6	7
0	Pro	P/C	Audio?	Emphasis			Locked	Sample Freq.	
0	Con	P/C	Audio?	Copy	Emphasis			Mode	

It becomes obvious that the meaning of the following bits differs quite substantially between the two formats. If a device like a common DAT recorder only has an SPDIF input, it usually understands only this format. In most cases, it will switch off when being fed Professional-coded data. The table shows that a Professional-coded signal would lead to malfunctions for copy prohibition and emphasis, if being read as Consumer-coded data.

Nowadays many devices with SPDIF input can handle Professional subcode. Devices with AES3 input almost always accept Consumer SPDIF (passive cable adapter required).

18.8 Signal to Noise Ratio in DS- / QS-Operation

The outstanding signal to noise ratio of the Micstasy's AD-converters can be verified even without expensive test equipment, by using record level meters of various software. But when activating the DS and QS mode, the displayed noise level will rise from -115 dBFS to -112 dBFS at 96 kHz, and -79 dBFS at 192 kHz. This is not a failure. The software measures the noise of the whole frequency range, at 96 kHz from 0 Hz to 48 kHz (RMS unweighted), at 192 kHz from 0 Hz to 96 kHz.

When limiting the measurement's frequency range to 22 kHz (audio bandpass, weighted) the value would be -115 dB again. This can be verified even with RME's Windows tool *DIGICheck*. Although a dBA weighted value does not include such a strong bandwidth limitation as audio bandpass does, the displayed value of -107 dBFS is nearly identical to the one at 48 kHz.

Subframe	MSB	Audio Data	LSB	AUX	CUV	RMS [dB+3]	RMS [dBA+3]	DC [dB]
1 - Left	*****	*****	*****	*****	000	-78.5	-107.2	-146.9
2 - Right	*****	*****	*****	*****	000	-78.5	-107.2	-144.9
Bits	4	8	12	16	20	24		

Press F1 for help. SR 192kHz

The reason for this behaviour is the noise shaping technology of the analog to digital converters. They move all noise and distortion to the in-audible higher frequency range, above 45 kHz. Therefore the noise is slightly increased in the ultrasound area. High-frequency noise has a high energy. Add the quadrupled bandwidth, and a wideband measurement will show a significant drop in SNR, while the human ear will notice absolutely no change in the audible noise floor.

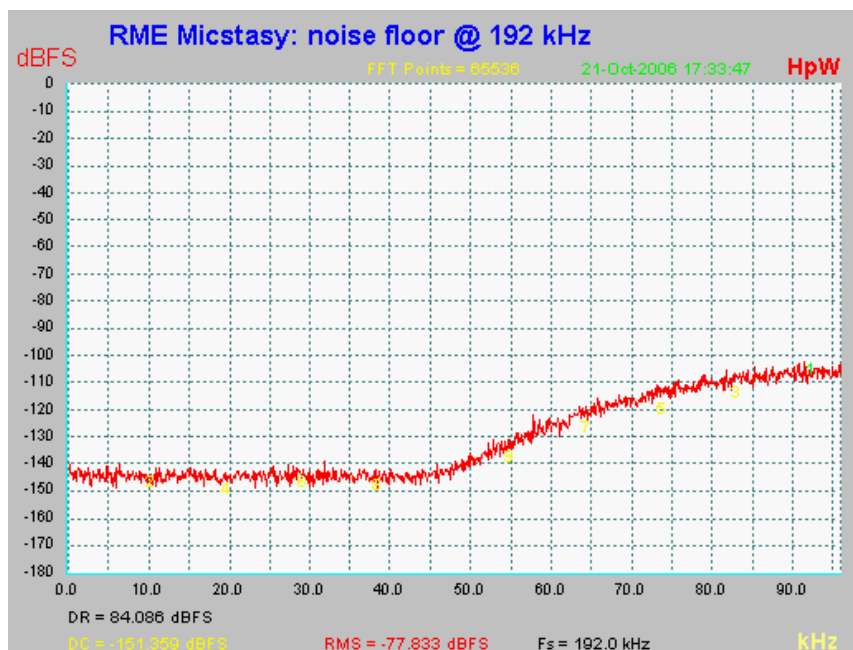

As can be seen in the above picture, the noise floor stays fully unchanged up to 45 kHz. With sample rates up to 96 kHz the noise shaping completely happens outside of the transmission range.

18.9 MADl Basics

MADl, the serial **M**ultichannel **A**udio **D**igital Interface, has been defined already in 1989 as an extension of the existing AES3 standard following several manufacturers' wish. The format also known as AES/EBU, a balanced bi-phase signal, is limited to two channels. Simply put, MADl contains 28 of those AES/EBU signals in serial, i. e. after one another, and the sample rate can still even vary by +/-12.5%. The limit which cannot be exceeded is a data rate of 100Mbit/s.

Because an exact sampling frequency is used in most cases, the 64 channel mode was introduced officially in 2001. It allows for a maximum sample rate of 48 kHz + ca. 1%, corresponding to 32 channels at 96 kHz, without exceeding the maximum data rate of 100 Mbit/s. The effective data rate of the port is 125 Mbit/s due to additional coding.

Older devices understand and generate only the 56 channel format. Newer devices often work in the 64 channel format, but offer still no more than 56 audio channels. The rest is being eaten up by control commands for mixer settings etc.. The Micstasy shows that this can be done in a much better way, with an invisible transmission of 16 MIDI channels plus serial RS232 data stream, and the 64-channel MADl signal still being 100% compatible.

For the transmission of the MADl signal, proved methods known from network technology were applied. Most people know unbalanced (coaxial) cables with 75 Ohms BNC plugs, they are not expensive and easy to get. The optical interface is much more interesting due to its complete galvanic separation, but for many users it is a mystery, because very few have ever dealt with huge cabinets full of professional network technology. Therefore here are some explanations regarding 'MADl optical'.

- The cables used are standard in computer network technology. They are thus not at all expensive, but unfortunately not available in every computer store.
- The cables have an internal fibre of only 50 or 62.5 µm diameter and a coating of 125 µm. They are called network cables 62.5/125 or 50/125, the former mostly being blue and the latter mostly being orange. Although in many cases not clearly labelled, these are always (!) glass fibre cables. Plastic fibre cables (POF, plastic optical fibre) can not be manufactured in such small diameters.
- The plugs used are also an industry standard and called SC. Please don't mix them up with ST connectors, which look similar to BNC connectors and are being screwed. Plugs used in the past (MIC/R) were unnecessarily big and are not being used any longer.
- The cables are available as a duplex variant (2 cables being glued together) or as a simplex variant (1 cable). The Micstasy's opto module supports both variants.
- The transmission uses the multimode technique which supports cable lengths of up to almost 2 km. Single mode allows for much longer distances, but it uses a completely different fibre (8 µm). By the way, due to the wave-length of the light being used (1300 nm), the optical signal is invisible to the human eye.

18.10 SteadyClock

The SteadyClock technology of the Micstasy guarantees an excellent performance in all clock modes. Its highly efficient jitter suppression refreshes and cleans up any clock signal, and provides it as reference clock at the word clock output.

Usually a clock section consists of an analog PLL for external synchronization and several quartz oscillators for internal synchronisation. SteadyClock requires only one quartz, using a frequency not equalling digital audio. Latest circuit designs like hi-speed digital synthesizer, digital PLL, 100 MHz sample rate and analog filtering allow RME to realize a completely newly developed clock technology, right within the FPGA at lowest costs. The clock's performance exceeds even professional expectations. Despite its remarkable features, SteadyClock reacts quite fast compared to other techniques. It locks in fractions of a second to the input signal, follows even extreme varipitch changes with phase accuracy, and locks directly within a range of 28 kHz up to 200 kHz.

SteadyClock has originally been developed to gain a stable and clean clock from the heavily jittery MAD1 data signal. The embedded MAD1 clock suffers from about 80 ns jitter, caused by the time resolution of 125 MHz within the format. Common jitter values for other devices are 5 ns, while a very good clock will have less than 2 ns.

The picture to the right shows the MAD1 input signal with 80 ns of jitter (top graph, yellow). Thanks to SteadyClock this signal turns into a clock with less than 2 ns jitter (lower graph, blue).

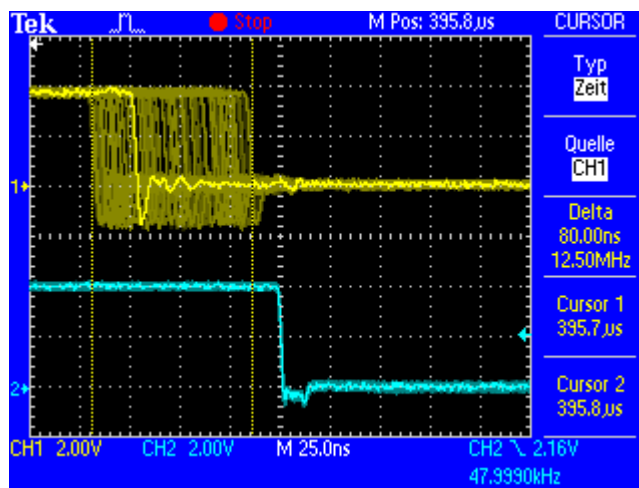

Using the other input sources of the Micstasy, word clock and AES/EBU, you'll most probably never experience such high jitter values. But SteadyClock is not only ready for them, it would handle them just on the fly.

The screenshot to the right shows an extremely jittery word clock signal of about 50 ns jitter (top graph, yellow). Again SteadyClock provides an extreme clean-up. The filtered clock shows less than 2 ns jitter (lower graph, blue).

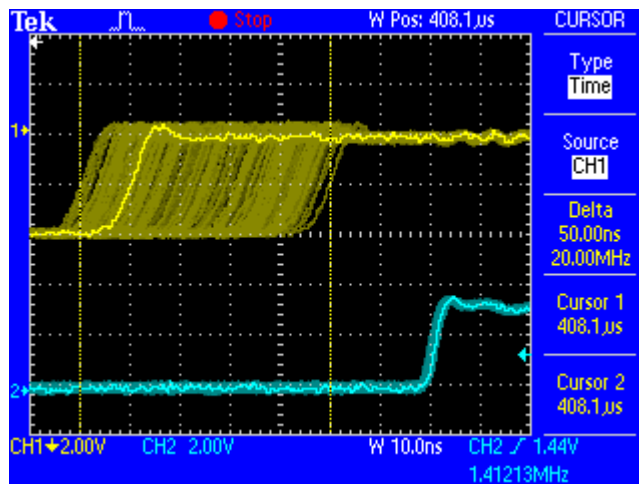

The cleaned and jitter-freed signal can be used as reference clock for any application, without any problem. The signal processed by SteadyClock is of course not only used internally, but also available at the Micstasy's word clock output. It is also used to clock the digital outputs MAD1 and AES/EBU.

19. Block Diagram

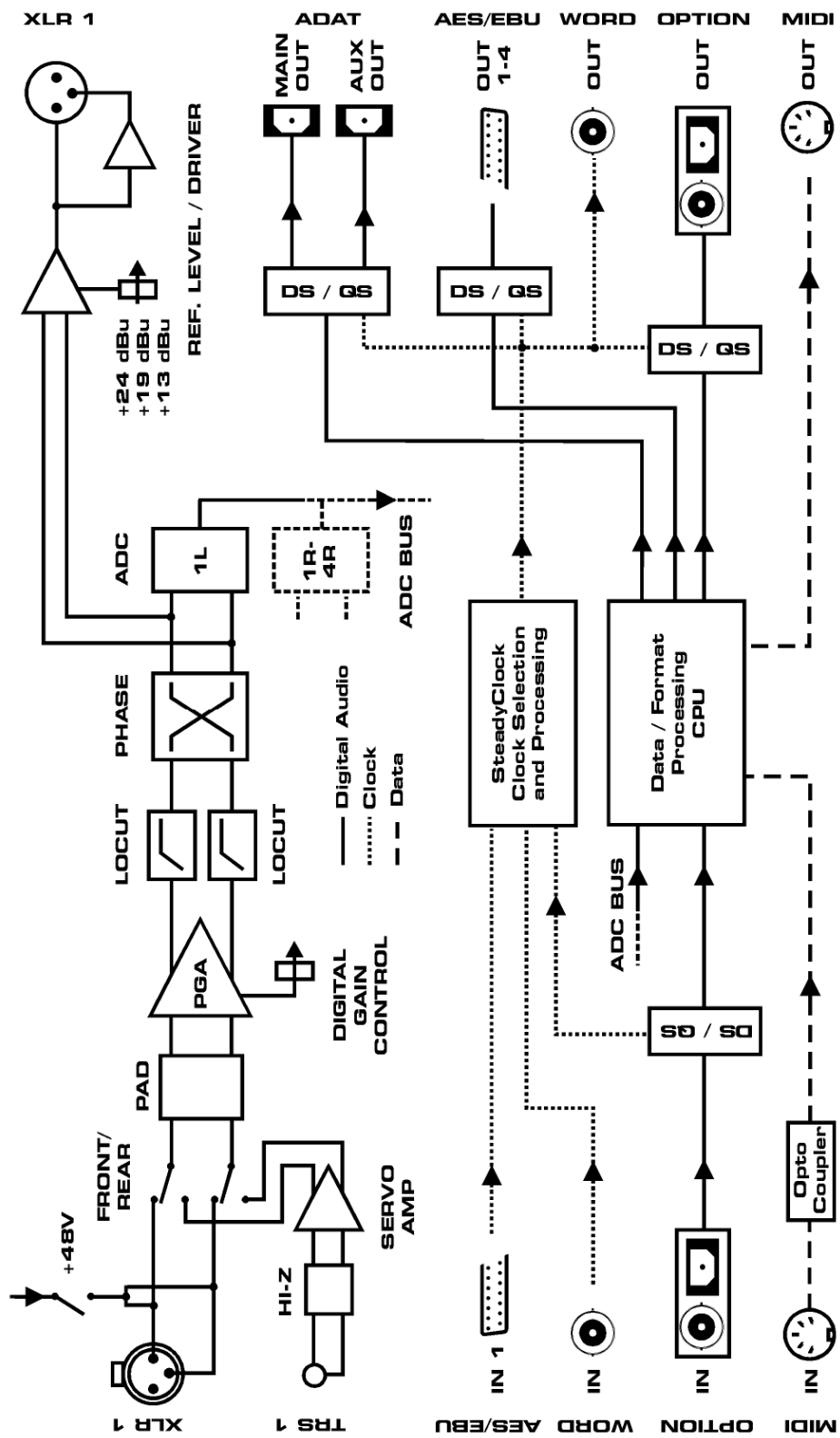

20. MIDI Implementation Micstasy

20.1 Basic SysEx Format

<u>Value</u>	<u>Name</u>
F0h	SysEx header
00h 20h 0Dh	MIDITEMP manufacturer ID
68h	Model ID (Micstasy)
00h..7Eh, 7Fh	Bank number / device ID (7Fh = broadcast, all IDs)
mm	Message type
nn	Parameter number (see table 1)
oo	Data byte
F7h	EOX

Bank Number / Device ID

The lower nibble refers to the device ID (0..7), the higher nibble refers to the bank number (0..7), e. g. 25h means bank 2, device 5. 7Fh addresses all banks and all devices.

20.2 Message Types

<u>Value</u>	<u>Name</u>
10h	Request value
11h	Request level meter data
20h	Set value
30h	Value response
31h	Level meter data response

Request Value

Format: F0 00 20 0D 68 (bank no. / dev ID) 10 F7

This string triggers a complete dump of all value response data bytes.

Value Response

After being triggered by receiving a request value command, device sends a string of all value response data bytes. Message type is set to 30h.

Set Value

Sets any number of parameters.

nn / oo can be repeated freely.

Request Level Meter Data

Format: F0 00 20 0D 68 (Bank no. / dev ID) 11 F7

This string triggers a shorter dump of only the level meter data.

Level Meter Response

After being triggered by receiving a request level meter data command, device sends a string of all level meter data bytes. Message type is set to 31h.

Level Meter Data Response Format

F0 00 20 0D 68 (bank no. / dev ID) 31 (ch.1) (ch.2) (ch.3) (ch.4) (ch.5) (ch.6) (ch.7) (ch.8) F7

The peak level value will be stored and transmitted with the next level meter data request, and the stored value will be reset.

20.3 Table

No.	No.	Name	Set Val.	Val. Resp.	Data bytes
00h	0	Ch. 1 Gain coarse	x	x	0..85 = -9..+76dB, 1dB steps
01h	1	Ch. 1 Gain fine	x	x	(see gain fine settings table)
02h	2	Ch. 1 settings	x	x	(see channel settings table)
03h	3	Ch. 2 Gain coarse	x	x	0..85 = -9..+76dB, 1dB steps
04h	4	Ch. 2 Gain fine	x	x	(see gain fine settings table)
05h	5	Ch. 2 settings	x	x	(see channel settings table)
06h	6	Ch. 3 Gain coarse	x	x	0..85 = -9..+76dB, 1dB steps
07h	7	Ch. 3 Gain fine	x	x	(see gain fine settings table)
08h	8	Ch. 3 settings	x	x	(see channel settings table)
09h	9	Ch. 4 Gain coarse	x	x	0..85 = -9..+76dB, 1dB steps
0Ah	10	Ch. 4 Gain fine	x	x	(see gain fine settings table)
0Bh	11	Ch. 4 settings	x	x	(see channel settings table)
0Ch	12	Ch. 5 Gain coarse	x	x	0..85 = -9..+76dB, 1dB steps
0Dh	13	Ch. 5 Gain fine	x	x	(see gain fine settings table)
0Eh	14	Ch. 5 settings	x	x	(see channel settings table)
0Fh	15	Ch. 6 Gain coarse	x	x	0..85 = -9..+76dB, 1dB steps
10h	16	Ch. 6 Gain fine	x	x	(see gain fine settings table)
11h	17	Ch. 6 settings	x	x	(see channel settings table)
12h	18	Ch. 7 Gain coarse	x	x	0..85 = -9..+76dB, 1dB steps
13h	19	Ch. 7 Gain fine	x	x	(see gain fine settings table)
14h	20	Ch. 7 settings	x	x	(see channel settings table)
15h	21	Ch. 8 Gain coarse	x	x	0..85 = -9..+76dB, 1dB steps
16h	22	Ch. 8 Gain fine	x	x	(see gain fine settings table)
17h	23	Ch. 8 settings	x	x	(see channel settings table)
18h	24	Setup 1	x	x	(see setup 1 table)
19h	25	Setup 2	x	x	(see setup 2 table)
1Ah	26	Lock / Sync Info		x	(see lock / sync table)
1Bh	27	Memory Save	x		0 = idle, 1..8 save memory 1..8
1Ch	28	Memory Recall	x		0 = idle, 1..8 recall memory 1..8
1Dh	29	Set Bank No. / Dev. ID	x		00h..77h, 7Fh
1Eh	30	Oscillator	x		0 = off, 1..8 = Channel 1..8

		Gain Fine Settings	MSB / 7		0
		(Channel 1)	6		Display auto dark: 0 = off, 1 = on
		(Request only)	5	MSB / 3	Level: 0 = < -70dBFS peak
		(Request only)	4	/ 2	Level: 1..12 = < -60 / -50 / -42 / -36 / -30 / -24 /
		(Request only)	3	/ 1	Level: -18 / -12 / -6 / -3 / -1 / -0.1 dBFS
		(Request only)	2	LSB / 0	Level: 13 = > -0.1 dBFS (over)
		(Channels 2..8)	1		AutoSet Link: 0 = off, 1 = link to lower channel Channel 1: digital out AES/ADAT 0 = analog, 1 = Option
			LSB / 0		Gain fine: 0 = 0dB, 1 = +0.5dB

		Channel Settings	MSB / 7		0
			6		P48: 0 = off, 1 = on
			5		Phase: 0 = normal, 1 = inverted
			4		M/S: 0 = off, 1 = on (set only ch. 1, 3, 5, 7)
			3		Lo Cut: 0 = off, 1 = on
			2		Autoset: 0 = off, 1 = on
			1		Hi Z: 0 = off, 1 = on
			LSB / 0		Input: 0 = rear, 1 = front

18h		Setup 1	MSB / 7		0
			6	MSB / 1	analog output: 0 = +13dBu, 1 = +19dBu,
			5	LSB / 0	analog output: 2 = +24dBu
			4	MSB / 1	clock select: 0 = int., 1 = Option,
			3	LSB / 0	clock select: 2 = AES, 3 = WCK
			2	MSB / 1	clock range: 0 = single speed, 1 = ds, 2 = qs
			1	LSB / 0	clock range
		(d.c. for clock sel > 0)	LSB / 0		int. freq.: 0 = 44.1kHz, 1 = 48kHz

19h		Setup 2	MSB / 7		0
			6		Auto-Device: 0 = off, 1 = on
			5		Delay Compensation: 0 = off, 1 = on
			4	MSB / 1	Autoset-Limit: 0 = -1dB, 1 = -3dB, 2 = -6dB,
			3	LSB / 0	3 = -12dB
			2		Follow Clock: 0 = off, 1 = on
			1		Peak Hold: 0 = off, 1 = on
			LSB / 0		Lock Keys: 0 = unlock, 1 = lock

1Ah		Lock / Sync	MSB / 7		0
			6		WC Out: 0 = Fs, 1 = Single Speed
			5		WCK Sync: 0 = no sync, 1 = sync
			4		WCK Lock: 0 = unlock, 1 = lock
			3		AES Sync: 0 = no sync, 1 = sync
			2		AES Lock: 0 = unlock, 1 = lock
			1		Option Sync: 0 = no sync, 1 = sync
			LSB / 0		Option Lock: 0 = unlock, 1 = lock

Request Level Meter Data

		Level Meter Data	MSB / 7		0
			6		0
			5		0
			4		0
			3	MSB / 3	Level: 0 = < -70dBFS peak
			2	/ 2	Level: 1..12 = < -60 / -50 / -42 / -36 / -30 / -24 /
			1	/ 1	Level: -18 / -12 / -6 / -3 / -1 / -0.1 dBFS
			LSB / 0	LSB / 0	Level: 13 = > -0.1 dBFS (over)

20.4 Pro Tools MIDI Compatibility

The Micstasy is MIDI remote compatible to Digidesign's Pro Tools system. The extended functionality of the Micstasy (e.g. much smaller gain steps) is not available here, because the Digidesign protocol does not support those features.

The Pro Tools micpre MIDI protocol uses simple controller messages and is therefore unprotected. Other MIDI devices like keyboards etc. shall not be active on the same MIDI line, otherwise certain values within the Micstasy will most probably be changed randomly. Because of this, the Pro Tools compatibility is switched off by default, and has to be activated via the Setup menu if required.

MIDI channel	Bank	ID	MIDI channel	Bank	ID
1	1	1	9	2	1
2	1	2	10	2	2
3	1	3	11	2	3
4	1	4	12	2	4
5	1	5	13	2	5
6	1	6	14	2	6
7	1	7	15	2	7
8	1	8	16	2	8

To address more than one Micstasy from within Pro Tools simply change the Bank and ID number of the units according to the table on the left.

Micstasy / Pro Tools Mic Pre MIDI Table *italics: PT parameters, not used*

<p>BXh cc vv</p> <p>X = Device ID + Bank ID Bank 1 Device 1 .. Bank 2 Device 8</p> <p>cc = Controller high nibble channel (0 = ch.1, 7 = ch.8) low nibble parameter</p> <p>vv = Value</p> <p>BXh 0Eh = reset to default</p>
--

Yc	Name	Vv
(Y = channel (0 = ch. 1, 7 = ch. 8))		
Y0h	Input Source	00h = mic / line (rear), 01h = instrument (front) 02h = instrument (front)
Y1h	Input Impedance	00h = 2k, 02h = 1M (<i>01h not used</i>)
Y2h	PAD 18dB	00h = no PAD, 7Fh = PAD 18dB
<i>Y3h</i>	<i>Insert</i>	<i>not used</i>
Y4h	Phantom Power 48V	00h = off, 7Fh = on
Y5h	Phase	00h = normal, 7Fh = inverted
Y6h	Low Cut	00h = off, 7Fh = on
<i>Y7h</i>	<i>Mute</i>	<i>not used</i>
Y9h	Gain (coarse)	00h = 0dB, 01h = +3dB, ..., 19h = +75dB (orig. PT 00h...17h = 0dB...+69dB)

20.5 Yamaha MIDI Compatibility

Since firmware 2.0 the Micstasy is directly compatible to Yamaha's mixing desk PM5D. It reacts on the Sysex commands. Adjustable are: Input Gain in steps of 1 dB (gain range -9 up to +63 dB) and Phantom power per channel.

The Yamaha DM1000 / DM2000 consoles are not directly compatible, but still can remote control several Micstasys via MIDI. To achieve this, the MIDI Remote Layer function of the consoles have to be set so that they match the Micstasy's SysEx remote protocol.

The following text gives instructions for the necessary settings.

DM1000

On the 'Setup – MIDI/Host' page, chose 'MIDI' for the remote layer that is going to be used. Don't forget to confirm your choice with 'enter'!

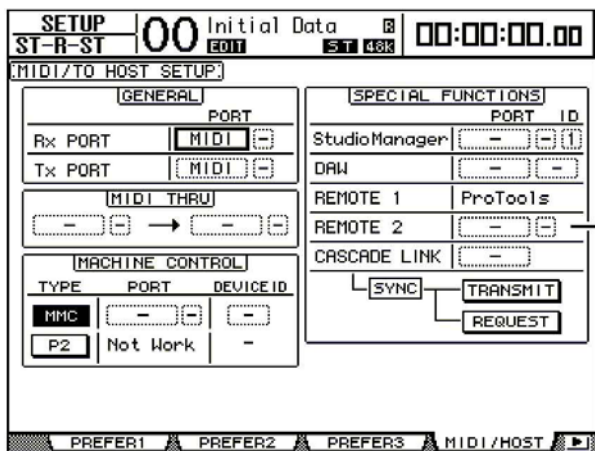

On the 'Remote 1' or 'Remote 2' page, enter the SysEx commands described below for each channel. In the 'Layer' section, select the 'Remote 1' or 'Remote 2' layer and select each respective channel with the 'select' button.

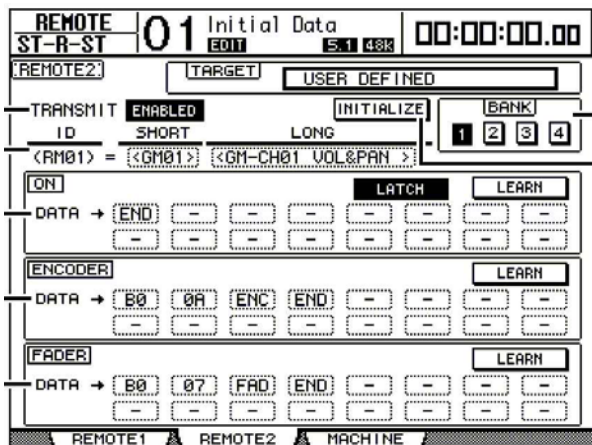

DM2000

On the 'Setup – MIDI/Host' page, choose 'MIDI' for the remote layer that is going to be used. Don't forget to confirm your choice with 'enter'!

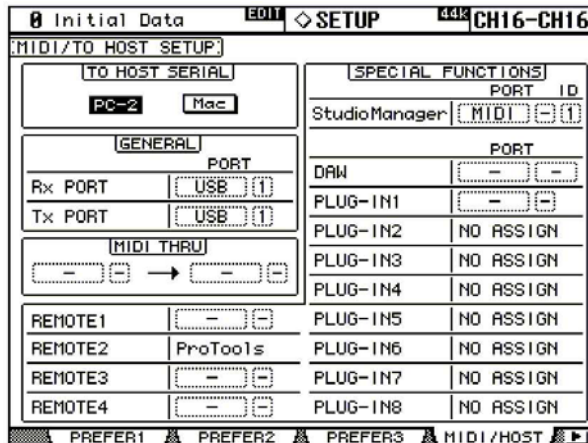

On the Remote pages 1 to 4, enter the SysEx commands described below for each channel. In the 'Layer' section, select the Remote layer 1 to 4 and select each channel with the 'select' button.

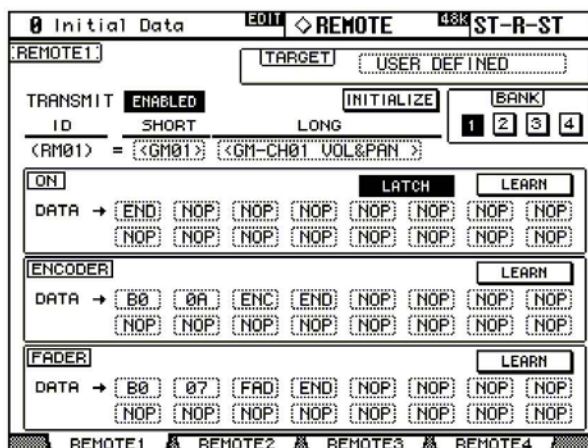

We recommend the use of the encoders to remote control the Micstasy's gain values. Unfortunately, the described settings have to be made from scratch for every channel.

In the encoder field of the Remote page, insert the following MIDI bytes:

F0, 00, 20, 0D, 68, (bank / ID), 20, (channel gain coarse), ENC, (channel gain fine), 00, F7, END

For the first group of 8 channels (Micstasy Bank = 1, ID = 1), set bank / ID to 00, for the second group of 8 channels (Micstasy Bank = 1, ID = 2), set bank / ID to 01, and so on.

The Banks 2..8 can be addressed by setting bank / ID to 1x..7x, if necessary.

The 'channel gain coarse' and 'channel gain fine' bytes have to be set according to the following table:

Channel	coarse	fine
1	00	01
2	03	04
3	06	07
4	09	0A
5	0C	0D
6	0F	10
7	12	13
8	15	16

Note: Setting the 'channel gain fine' byte to 00 as described above also deactivates the AutoSet function. This is necessary, because the Micstasy's gain settings are not transmitted to the console. Without deactivating AutoSet, a channel which has its gain changed by AutoSet will automatically be set to the console's remote value again, as soon as the encoder is moved or a scene memory is recalled.

Examples

Micstasy No. 1, Channel 1:

F0	00	20	0D	68	00	20	00
ENC	01	00	F7	END			

Micstasy No. 1, Channel 2:

F0	00	20	0D	68	00	20	03
ENC	04	00	F7	END			

Micstasy No. 2, Channel 3:

F0	00	20	0D	68	01	20	06
ENC	07	00	F7	END			

Micstasy No. 3, Channel 4:

F0	00	20	0D	68	02	20	09
ENC	0A	00	F7	END			