

User's Guide



ADI-2

SyncAlign™

SyncCheck™

Intelligent Clock Control™

SteadyClock™

Hi-Precision 24 Bit / 192 kHz
2-Channel AD / DA-Converter
AES / SPDIF / ADAT Interface
Hi-Power Hi-End Headphone Output



AES/EBU

192 kHz / 24 Bit Interface

Contents

1	Introduction	3
2	Supplied Contents	3
3	Brief Description and Characteristics	3
4	Technical Specifications	
4.1	Analog Specs	4
4.2	Digital Specs	5
4.3	Digital Interface	5
5	Power Supply	5
6	First Usage - Quick Start	6
7	Inputs and Outputs	
7.1	Analog Inputs	7
7.2	Analog Outputs	8
7.3	Headphones.....	9
7.4	Digital Inputs	9
7.5	Digital Outputs.....	10
8	Clock Section	11
9	Noise Level in DS / QS Mode	12
10	SteadyClock	12
11	Controls and Connectors	13
12	Connector Pinouts	14
13	Firmware	14
14	Block Diagram	15
15	Warranty	16
16	Appendix	16

1. Introduction

Congratulations on your purchase of a ADI-2. This hi-quality analog to digital and digital to analog converter includes AES/SPDIF and ADAT optical digital interfaces. It represents a sophisticated, highly flexible and universal tool. Advanced circuit technology combined with latest integrated circuits result in a unique and outstanding device, meeting highest quality standards. The ADI-2 will excite you even after many years of operation.

2. Supplied Contents

Please check that your ADI-2's package contains each of the following:

- ADI-2
- User's guide
- Power supply 12 V / 2 A and power cord

3. Brief Description and Characteristics

The ADI-2 is a 2-channel analog to digital and digital to analog converter in a half-rack (9.5") enclosure of 1 U height. Latest 24 bit / 192 kHz converters offer up to 119 dBA dynamic ratio. This value is not only printed in the brochure - thanks to our Low Jitter Design it is available with every sold unit.

The servo balanced analog inputs and outputs are fitted with both XLR and 1/4" TRS jacks. The signal path from the jacks to the ADC is completely symmetrical. Both signal paths A/D and D/A are internally DC-coupled, for highest phase accuracy at lowest roll-off. The hi-power/hi-end headphone output provides reference sound. The digital inputs and outputs are available as AES/EBU, SPDIF coaxial and optical, as well as ADAT optical.

To maintain the full dynamic range within the best operating level, RME's ADI-2 includes electronic switches of the latest technology, which introduce no additional noise or distortion to the audio path. Two switches on the front panel let you control input and output level for a perfect adaptation to the most often used standards -10 dBV and +4 dBu. Two compact level meters provide 6 LEDs each. Multiple brightness stages and peak hold functionality make reading and adjusting input levels easy and convenient.

The ADI-2 can provide all sample rates between 32 kHz and 192 kHz. The unique Intelligent Clock Control technology (ICC) offers a flexible operation with internal clock and the digital input signals. Furthermore, RME's SteadyClock guarantees exceptional performance in all clock modes. Thanks to a highly efficient jitter suppression, the AD-conversion always operates on highest sonic level, being completely independent from the quality of the incoming clock signal.

4. Technical Specifications

- Power supply: external switching power supply, 100 - 240 V AC, 20 Watts
- Accepted power supply voltage: DC 8 V – 28 V, AC 8 V – 20 V
- Current at 12 V: 670 mA (8 Watts)
- Dimensions including rack ears (WxHxD): 265 x 44 x 165 mm (10.5" x 1.73" x 6.5")
- Dimensions without rack ears/handles (WxHxD): 218 x 44 x 155 mm (8.6" x 1.73" x 6.1")
- Weight: 1 kg (3.3 lbs)
- Temperature range: +5° up to +50° Celsius (41° F up to 122°F)
- Relative humidity: < 75%, non condensing

4.1 Analog Specs

AD

- Resolution AD: 24 bit
- Signal to Noise ratio: 110 dB RMS unweighted, 113 dBA
- Frequency response AD @ 44.1 kHz, -0.1 dB: 5 Hz - 21.5 kHz
- Frequency response AD @ 96 kHz, -0.5 dB: 5 Hz – 45.3 kHz
- Frequency response AD @ 192 kHz, -1 dB: 5 Hz - 74 kHz
- THD: < -110 dB, < 0.00032 %
- THD+N: < -104 dB, < 0.00063 %
- Crosstalk: > 110 dB
- Maximum input level AD: +19 dBu
- Input: XLR or 1/4" TRS, electronically balanced
- Input impedance: 10 kOhm
- Input sensitivity switchable: +4 dBu, -10 dBV, Lo Gain
- Input level for 0 dBFS @ Lo Gain: +19 dBu
- Input level for 0 dBFS @ +4 dBu: +13 dBu
- Input level for 0 dBFS @ -10 dBV: +2 dBV

DA

- Resolution DA: 24 Bit
- Signal to Noise ratio (SNR): 116 dB RMS unweighted, 119 dBA @ 44.1 kHz (unmuted)
- Frequency response @ 44.1 kHz, -0.1 dB: 1 Hz – 21.1 kHz
- Frequency response @ 96 kHz, -0.5 dB: 1 Hz – 43.5 kHz
- Frequency response @ 192 kHz, -1 dB: 1 Hz – 70 kHz
- THD: -103 dB, < 0.0007 %
- THD+N: -100 dB, < 0.0001 %
- Crosstalk: > 110 dB
- Maximum output level DA: +19 dBu
- Output: XLR and 1/4" TRS, servo balanced
- Output impedance: 75 Ohm
- Output level switchable: Hi Gain, +4 dBu, -10 dBV
- Output level at 0 dBFS @ Hi Gain: +19 dBu
- Output level at 0 dBFS @ +4 dBu: +13 dBu
- Output level at 0 dBFS @ -10 dBV: +2 dBV

DA - Stereo Monitor Output (Phones)

- as DA, except:
- Output: 6.3 mm stereo TRS, unbalanced
- Output impedance: 30 Ohm

4.2 Digital Specs

- Clocks: Internal, ADAT In, SPDIF In
- Low jitter design: < 1 ns in PLL mode, all inputs
- Internal clock: 800 ps jitter, random spread spectrum
- Jitter suppression of external clocks: about 30 dB (2.4 kHz)
- Effective clock jitter influence on AD and DA conversion: near zero
- PLL ensures zero dropout, even at more than 100 ns jitter
- Digital Bitclock PLL for trouble-free varispeed ADAT operation
- Supported sample rates: 30 kHz up to 200 kHz

4.3 Digital Interface

- Digital inputs and outputs ground-free transformer coupled
- Formats: optical (TOSLINK), RCA (SPDIF, AES/EBU compatible)
- High-sensitivity input stage RCA: < 0.2 V_{pp} input level
- Output voltage RCA Consumer 0.8 V, Professional 2.3 V

5. Power Supply

In order to make operating the ADI-2 as flexible as possible, the unit contains a switching regulator of the latest technology, which not only has a high efficiency (> 90%), but also prevents internal hum noise by operating beyond 100 kHz. Another advantage: the ADI-2 accepts any power supply with voltages between 8 and 28 V DC, no matter which polarity, and even between 8 and 20 V AC. Given the power supply can deliver the current needed.

The supplied high-quality switching power supply, 12 V / 2 A, not only accepts any mains voltage between 100 V and 240 V (usable world-wide), but is also fully regulated against voltage fluctuations. Additionally it only weighs 150 g in spite of its high power of 20 Watts.

The large voltage range of the ADI-2 also allows for the use of a rechargeable lead-battery instead of a power supply, for completely independent mobile operation. A matching connection cable (power jack to terminals 6.3 mm) is available from RME. A Panasonic LC-R122R2PG battery, 12 V 2.2 Ah, can operate the ADI-2 for 4 hours.

6. First Usage - Quick Start

Connect the TRS-jacks or the XLR connectors with the analog signal source. Change the input sensitivity by pressing INPUT - LEVEL until the input level is sufficient to avoid noisy operation. Try to achieve an optimum input level by adjusting the source itself. Raise the source's output level until the yellow –3 LEDs light up.

The analog line inputs of the ADI-2 can be used with +4 dBu and -10 dBV signals. The electronic input stage is built in a servo balanced design which handles monaural and stereo jacks correctly. When used unbalanced it automatically corrects the gain by 6 dB.

The digital output of the ADI-2 can be used as SPDIF, AES/EBU and ADAT optical source. The button OUTPUT sets the format:

- ADAT: The optical TOSLINK output operates in ADAT mode. Included support for Sample Split (S/MUX) enables sample rates up to 96 kHz.
- PRO: The output signal carries the Channel Status Professional. The physical output level at the RCA connector is raised, making the signal compatible to AES-3 and AES/EBU. The same signal is found at the optical output.
- CON: The output signal carries the Channel Status Consumer. The physical output level at the RCA connector is lowered. The same signal is found at the optical output.

On the analog playback side (the DA side), you just have to choose the desired digital input by pressing DIGITAL - INPUT. A coarse correction of the analog output level can be done by pressing OUTPUT LEVEL.

The output signal of the DA-converter is also available on the front, in the same quality as on the back. The level can be changed in a stepless way using the VOL pot. The very low impedance type output even allows for a connection of headphones.

The button INPUT LEVEL offers a fourth state (LEDs off), digital pass-through mode with analog monitoring (DA-converter). In this mode the AD-converter is not used. The level meters show the audio level of the digital input signal.

The ADI-2 stores all current settings and automatically activates them when the device is turned on.

Transferring digital data into a PCI bus equipped computer is best done using RME's digital interface cards of the Hammerfall® series. These hi-quality cards come with drivers for all popular operating systems. They have a world wide reputation as ultimate solution for master and multitrack tasks.

7. Inputs and Outputs

7.1 Analog Inputs

The ADI-2 provides balanced Line inputs via Neutrik combo jacks, XLR and 1/4" TRS. The electronic input stage is built in a servo balanced design which handles monaural and stereo jacks correctly. When used unbalanced it automatically corrects the gain by 6 dB.



When using unbalanced cables with XLR jacks, pin 3 of the cable's jack should be connected to pin 1 (ground). Otherwise noise may occur, caused by the unconnected negative input of the ADI's balanced input.

One of the main issues when working with an AD-converter is to maintain the full dynamic range within the best operating level. To achieve this, RME's ADI-2 includes a discrete hardware gain stage, directly in front of the AD-converter. Electronic switches of the latest technology, which introduce no additional noise or distortion to the audio path, are used to control the gain, and offer highest operating comfort. This way, the button INPUT - LEVEL allows a for convenient adaptation to the most often used studio levels -10 dBV and +4 dBu.

Level Meter

The 2-channel level meter with 6 LEDs each offers a useful display and check of input level and overloads. The LEDs make use of different brightness for different levels, so levels in between are easy to read out. This technology allows the ADI-2 to visualize a range of -76 dBFS up to -3 dBFS using only 5 LEDs.

The red OVR LED lights up dimmed at -2 dBFS, more bright at -1 dBFS. Reaching 0 dBFS it is fully lit. A peak hold function of one second ensures better visualization whenever the highest level is reached.

The table shows the level definition of the Level Meter, based on 0 dBFS. The actual input level in dBu can be calculated by adding the offset caused by the current choice of Input Level. Set to Lo Gain 19 dB have to be added, at +4 dBu a value of 13 dB has to be added (see below).

LED	Dim	Medium	Bright
OVR	-2	-1	0
-3 dB	-5	-4	-3
-6 dB	-8	x	-6
-12 dB	-24	-18	-12
-30 dB	-45	x	-30
-60 dB	-80	x	-60

Input Level definition

The 'standardized' studio levels do not result in a (often desired) full scale level, but take some additional digital headroom into consideration. The amount of headroom is different in different standards and again differently implemented by different manufacturers. Because of this we decided to define the levels of the ADI-2 in a most compatible way. The headroom of the ADI-2 is defined according to the chosen reference level.

Reference	0 dBFS @	Headroom
Lo Gain	+19 dBu	15 dB
+4 dBu	+13 dBu	9 dB
-10 dBV	+2 dBV	12 dB

At +4 dBu a headroom of 9 dB offers a problem-free operation with most devices, and meets the latest EBU recommendations for Broadcast usage. At -10 dBV 12 to 15 dB headroom are common practice, each mixing desk operating at -10 dBV is able to send and receive much higher levels. Lo Gain allows to work with high levels, best suited for professional users who prefer to work balanced and at highest levels.

7.2 Analog Outputs

The short circuit protected, low impedance and balanced line outputs are available as (stereo) 1/4" TRS jacks and XLR jacks. Both are internally connected, and can be used simultaneously. The electronic output stage is built in a servo balanced design which handles monaural and stereo jacks correctly. When used unbalanced it automatically corrects the gain by 6 dB.

To maintain an optimum level for devices connected to the analog outputs, the ADI-2 includes a discrete hardware gain stage, directly behind the DA-converter. Electronic switches of the latest technology, which introduce no additional noise or distortion to the audio path, are used to control the gain, and offer highest operating comfort. This way, the button OUPUT - LEVEL allows for a convinient adaptation to the most often used studio levels -10 dBV and +4 dBu.

As with the analog inputs, the analog output levels do not follow any single standard, but are designed to maintain a problem-free operation with most other devices. The headroom of the ADI-2 is defined according to the chosen reference level.

Reference	0 dBFS @	Headroom
Hi Gain	+19 dBu	15 dB
+4 dBu	+13 dBu	9 dB
-10 dBV	+2 dBV	12 dB

At +4 dBu a headroom of 9 dB offers a problem-free operation with most devices, and meets the latest EBU recommendations for Broadcast usage. At -10 dBV 12 to 15 dB headroom are common practice, each mixing desk operating at -10 dBV is able to send and receive much higher levels. Hi Gain provides maximum level for professional users who prefer to work balanced and at highest levels.

Option Fixed – Adjust

Since hardware revision 1.4* the ADI-2 includes an option to control the output level of the rear Line outputs via the VOL pot. To activate this option the device has to be opened:

1. Remove the rack ears
2. Remove the six screws that fix the cover
3. Slide the cover to the back

There are two tree-pin contacts in the unit, X 606 and X 607, having jumpers on them. See also the note printed on the PCB. In factory default the jumpers are placed in position **Fixed** (middle and left pin connected). The output level is defined only by the current OUTPUT LEVEL setting then. In jumper position **Adjust** (middle and right pin connected) the output level depends on both the OUTPUT LEVEL setting and the VOL pot position.

The double volume control realizes superior monitoring. Set the OUTPUT LEVEL to +4, then adjust the monitoring volume with the VOL pot until it is perfect for you. Changing the OUTPUT LEVEL to Hi Gain gives a loudness boost of 6 dB, while setting it to -10 will reduce loudness by 9 dB – with the pot still unchanged!

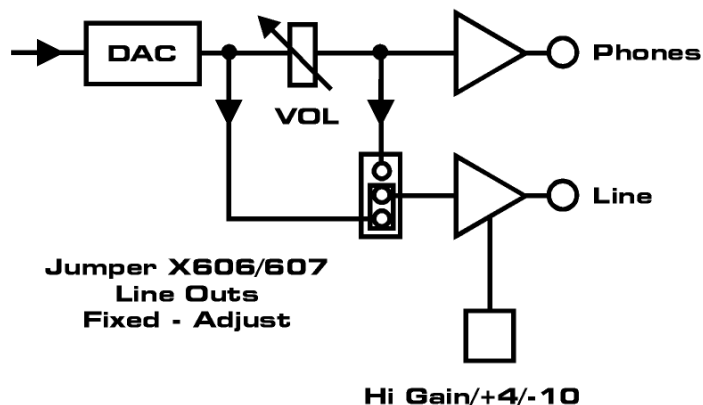

* The hardware revision 1.4 uses a white QS LED.

7.3 Headphones

The PHONES output on the front is fed from the DA-converter too. Although this output is not balanced, it still offers the same outstanding technical specifications as the rear outputs (e.g. 119 dBA SNR), so can be used as high quality Line output as well (see chapter 12, *Connector Pinouts*).

The level of the headphone output can be changed in a stepless way using the VOL pot. The special hi-power output design (30 Ohms) is not only of a very low impedance type, but also offers high headroom at up to +19 dBu output level.

7.4 Digital Inputs

The ADI-2 has a coaxial and an optical digital input.

The button INPUT sets the desired input active.

The digital input format is detected automatically. Be it AES, SPDIF or ADAT, further settings at the ADI-2 are not necessary. In case of ADAT optical only channels 1 and 2 are converted to analog, channels 3 to 8 are ignored.

To receive signals in AES/EBU format, an adapter cable is required. Pins 2 and 3 of a female XLR plug are connected individually to the two pins of a phono plug. The cable shielding is only connected to pin 1 of the XLR - not to the phono plug.

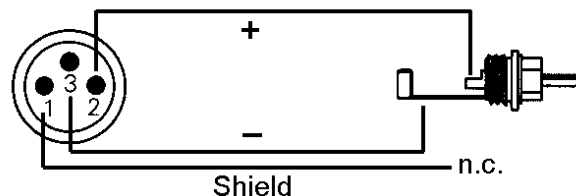

The ground-free design, with transformers for digital inputs and outputs, offers a trouble-free connection of all devices along with perfect hum rejection.

The ADAT optical inputs of the ADI-2 are fully compatible with all ADAT optical outputs. RME's unsurpassed Bitclock PLL prevents clicks and drop outs even in extreme varipitch operation, and guarantees a fast and low jitter lock to the digital input signal. A usual TOSLINK cable is sufficient for connection.

SPDIF Double/Quad Speed

Both the coaxial and optical input support all sample rates between 32 and 192 kHz directly. They operate in the so called Single Wire mode.

ADAT Double/Quad Speed

At sample rates above 48 kHz (Double/Quad Speed) ADAT uses *Sample Multiplexing (S/MUX)* to be able to operate at up to 192 kHz. The data of the channels 1 and 2 will be transmitted using channels 1/2 and 3/4 (S/MUX), or channels 1 to 8 (S/MUX4). The ADI-2 can receive and recombine data into 2 channels 96 kHz from all S/MUX compatible devices, like the Hammerfall, HDSP and ADI-8 series from RME.

Emphasis

The ADI-2's DA-converter supports Emphasis. This control information, only found in SPDIF/AES signals, causes the converter to reduce treble. (Note: this technology was used in the early days of digital audio, and is no longer used since years).



The button INPUT LEVEL offers a fourth state (LEDs off). In this mode the ADI-2 operates as Insert DA Converter. The Level Meter shows the audio level of the digital input signal, which is passed-through from input to output.

7.5 Digital Outputs

The ADI-2 has a coaxial and an optical digital output. The key OUTPUT sets the format:

- ADAT: The optical TOSLINK output operates in ADAT mode. Included support for Sample Split (S/MUX) enables sample rates up to 96 kHz.
- PRO: The output signal carries the Channel Status Professional. The physical output level at the RCA connector is raised, making the signal compatible to AES-3 and AES/EBU. The same signal is found at the optical output.
- CON: The output signal carries the Channel Status Consumer. The physical output level at the RCA connector is lowered. The same signal is found at the optical output.

In SPDIF/AES mode, identical signals are available at both the optical and the coaxial output. Therefore up to two devices can be connected, sending the same data to two different devices (splitter).

To send signals in AES/EBU format, an adapter cable is required. Pins 2 and 3 of a female XLR plug are connected individually to the two pins of a phono plug. The cable shielding is only connected to pin 1 of the XLR - not to the phono plug.

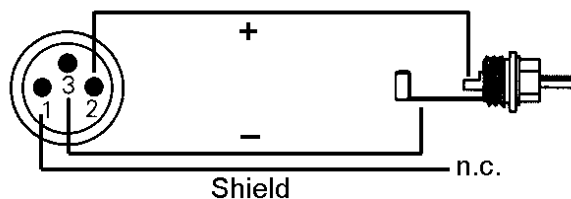

The ground-free design, with transformers for digital inputs and outputs, offers a trouble-free connection of all devices along with perfect hum rejection.

The optical SPDIF output can be used as ADAT output (OUTPUT – ADAT). The coaxial output continues to operate as AES/SPDIF output. The ADAT optical output of the ADI-2 is fully compatible to all ADAT optical inputs. A usual TOSLINK cable is sufficient for connection.

SPDIF Double/Quad Speed

Both the coaxial and optical output support all sample rates between 32 and 192 kHz directly. They operate in the so-called Single Wire mode.

ADAT Double/Quad Speed

At sample rates above 48 kHz (Double Speed) ADAT uses *Sample Multiplexing* (S/MUX) to be able to operate at up to 192 kHz. The data of the channels 1 and 2 will be transmitted using channels 1/2 and 3/4 (S/MUX) or 1 to 8 (SMUX/4). All devices compatible to S/MUX can receive and recombine the ADI-2's data into two channels 96 kHz, like the Hammerfall, HDSP and ADI-8 series from RME.

8. Clock Section

The ADI-2's unique clock section layout makes it easy to use, easy to understand and easy to read. Additionally RME's Intelligent Clock Control (ICC) enables a flexible operation of the AD- and DA-converter with internal clock or the digital input signals. A clear display of the lock and sync state further improves the clock section's usability.

The chosen clock state is valid for both AD- and DA-conversion simultaneously.

The key INPUT determines both the digital input being used for the DA-converter (coaxial or optical), and the external clock source in case CLOCK - INPUT has been selected. The lock state of the ADI-2 is indicated by a blinking (error) or constantly lit (Ok) INPUT LED (COAX, OPT).

In master mode (internal clock) a missing digital input signal causes the INPUT LED of the chosen input to flash. When using the ADI-2 as AD-converter only, the flashing LED becomes a normal state. In case an input signal is present but not in synchronicity to the internal clock, the CLOCK LED will flash.

Using external clock, the ADI-2 shows the range of the input signal's sample rate via the CLOCK LEDs. An external SPDIF or AES signal in Double or Quad Speed will cause the DS or QS LED to light up. With ADAT the input sample rate is always Single Speed. The real sample rate (Double or Quad Speed) therefore has to be set up manually by the user (push the CLOCK button so that either DS or QS light up).

Button CLOCK

This button sets the sample rate of the ADI-2, the unit will then be in clock mode master. However, with INPUT selected, the sample rate of the present digital input signal will be used as clock reference, the device then turns into clock mode slave.

Each push on the button CLOCK raises the sample frequency. When reaching the setting 48 kHz the DS LED lights up. The chosen frequency is now multiplied with a factor of 2. When reaching 48 kHz (now 96 kHz) again, the QS LED lights up. The chosen frequency is now multiplied with a factor of 4. When reaching 48 kHz (now 192 kHz) again, the INPUT LED lights up, then INPUT DS, then INPUT QS. Next the sample rate is back to 32 kHz and the scheme starts from the beginning. In case of SPDIF the incoming signal defines the status DS and QS. A manual selection is only necessary with ADAT.

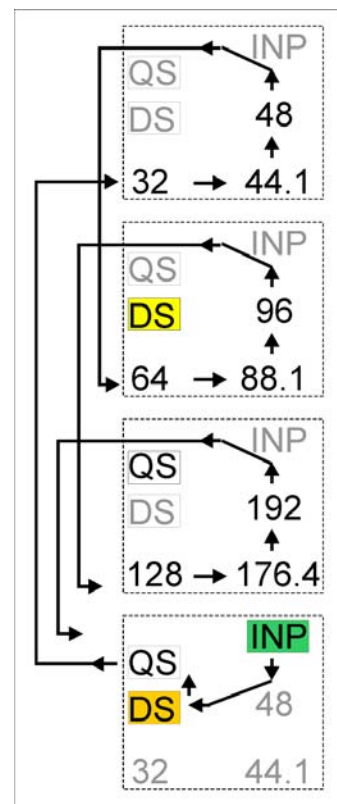

Clock mode D/A Internal

Clocking the DA-converter from the internal clock requires a synchronous operation of the attached device. To guarantee this the external device connected to the ADI-2 has to synchronize itself to the clock from SPDIF, AES or ADAT output of the ADI-2.

The ADI-2 has to be master, all attached devices slave. To prevent clicks caused by imperfect or even no synchronisation, a special method called *SyncCheck* compares the synchronicity of the incoming data with the internal clock of the ADI-2. The actual state is indicated by a blinking (error) or constantly lit (OK) CLOCK LED.



Only one device can be master in a digital system! When the ADI-2 operates with internal clock, all other devices have to be Slave.

9. Noise level in DS / QS Mode

The outstanding signal to noise ratio of the ADI-2 can be verified even without expensive test equipment, by using our famous *DIGICheck* tool or the record level meter of Steinberg's *WaveLab*. When activating the DS and QS mode, the displayed noise level will rise from -110 dB to -104 dB at 96 kHz, and -82 dB at 192 kHz. This is not a failure. This kind of measurement measures the noise of the whole frequency range, at 96 kHz from 0 Hz to 48 kHz (RMS unweighted), at 192 kHz even from 0 Hz to 96 kHz.

When limiting the measured area to 22 kHz (audio bandpass, weighted) the value would be -110 dB again. This can be verified even with RME's DIGICheck. Although a dBA weighted value does not include such a strong bandwidth limitation as from an audio bandpass, the displayed value of -108 dB is nearly identical to the one at 48 kHz.

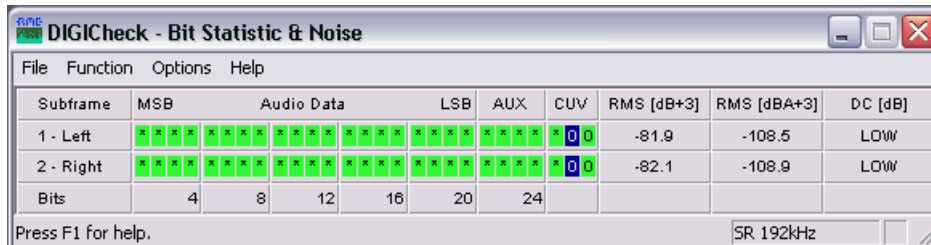

Subframe	MSB	Audio Data	LSB	AUX	CUV	RMS [dB+3]	RMS [dBA+3]	DC [dB]			
1 - Left	x	x	x	x	x	x	x	x	-81.9	-108.5	LOW
2 - Right	x	x	x	x	x	x	x	x	-82.1	-108.9	LOW
Bits	4	8	12	15	20	24					

The reason for this behaviour is the noise shaping technology of the analog to digital converters. They move all noise and distortion to the in-audible higher frequency range, above 24 kHz. That's how they achieve their outstanding performance and sonic clarity. Therefore the noise is slightly increased in the ultrasound area. High-frequent noise has a high energy. Add the doubled (quadrupled) bandwidth, and a wideband measurement will show a significant drop in SNR, while the human ear will notice absolutely no change in the audible noise floor.

10. SteadyClock

The ADI-2's SteadyClock technology guarantees an excellent performance in all clock modes. Thanks to a highly efficient jitter suppression, the AD- and DA-conversion always operate on highest sonic level, being completely independent from the quality of the incoming clock signal.

SteadyClock has been originally developed to gain a stable and clean clock from the heavily jittery MADI data signal (the embedded MADI clock suffers from about 80 ns jitter). Using the ADI-2's input signals SPDIF and ADAT, you'll most probably never experience such high jitter values. But SteadyClock is not only ready for them, it would handle them just on the fly.

Common interface jitter values in real world applications are below 10 ns, a very good value is less than 2 ns.

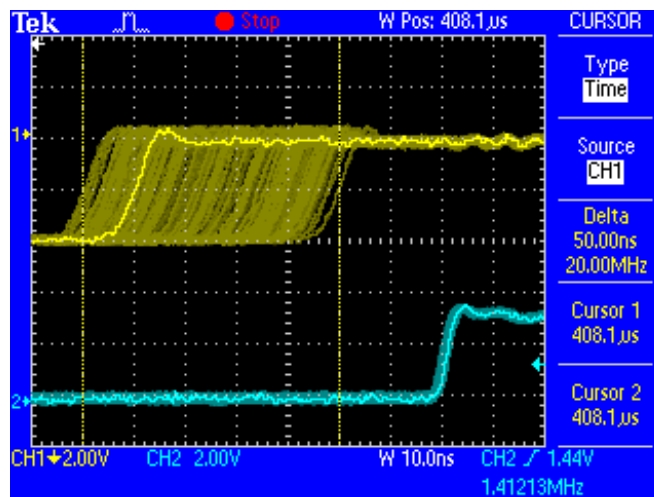

The screenshot shows an extremely jittery SPDIF signal of about 50 ns jitter (top graph, yellow). Thanks to SteadyClock this signal turns into a clock with less than 2 ns jitter (lower graph, blue). The signal processed by SteadyClock is of course not only used internally, but also used to clock the digital outputs. Therefore the refreshed and jitter-cleaned signal can be used as reference clock without hesitation.

11. Controls and Connectors

Front

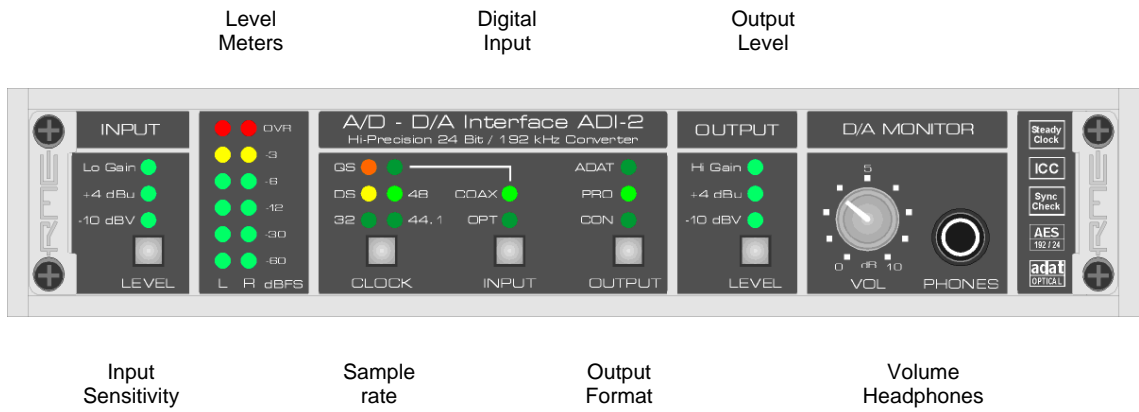

Input Sensitivity

Sample rate

Output Format

Volume Headphones

Rear



Power supply

Digital Inputs / Outputs

12. Connector Pinouts

TRS jacks of analog input / output

The stereo ¼" TRS jacks are wired according to international standards:

Tip = + (hot)
Ring = - (cold)
Sleeve = GND

The servo balanced input and output circuitry allows to use monaural TS jacks (unbalanced) with no loss in level. This is the same as when using a TRS-jack with ring connected to ground.

XLR jacks of analog input / output

The XLR connectors are wired according to international standards:

1 = GND (shield)
2 = + (hot)
3 = - (cold)

TRS Phones jack

The analog monitor output on the front is accessible through a stereo ¼" TRS jack. This allows a direct connection of headphones. In case the output should operate as Line output, an adapter TRS plug to RCA phono plugs, or TRS plug to TS plugs is required.

The pin assignment follows international standards. The left channel is connected to the tip, the right channel to the ring of the TRS jack/plug.

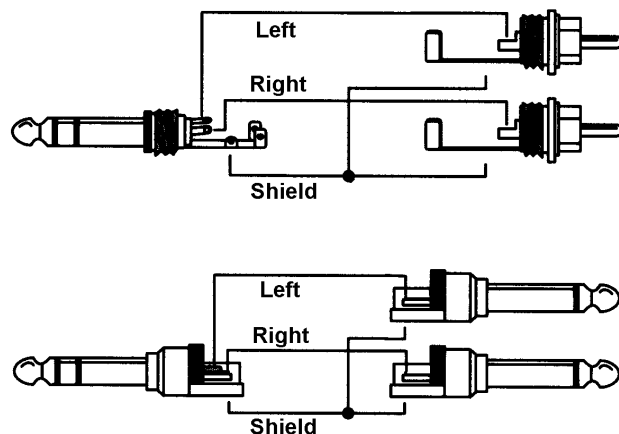

13. Firmware

The current firmware of the ADI-2 is version 1.4. This one is identical to version 1.3, except for a changed brightness of the white QS LED (formerly orange). Firmware 1.3 (10/2005) includes these improvements:

- No loud click anymore at changes of the input sample rate
- Support for ADAT S/MUX and S/MUX4 (ADAT up to 192 kHz)
- New function D-D. When the INPUT LEVEL button is pressed a fourth state 'LED Off' has been added. Instead of the AD-converter signal the digital input signal is fed to the DA-converter and to the digital output. The Level Meter displays the digital input data.
- Completely re-programmed ADAT PLL

The firmware version is shown after power-on of the unit on the Level Meters for a brief moment, with 1 for the lowest and 6 for the highest LED. The left channel shows the first number, the right channel the second number.

14. Block diagram

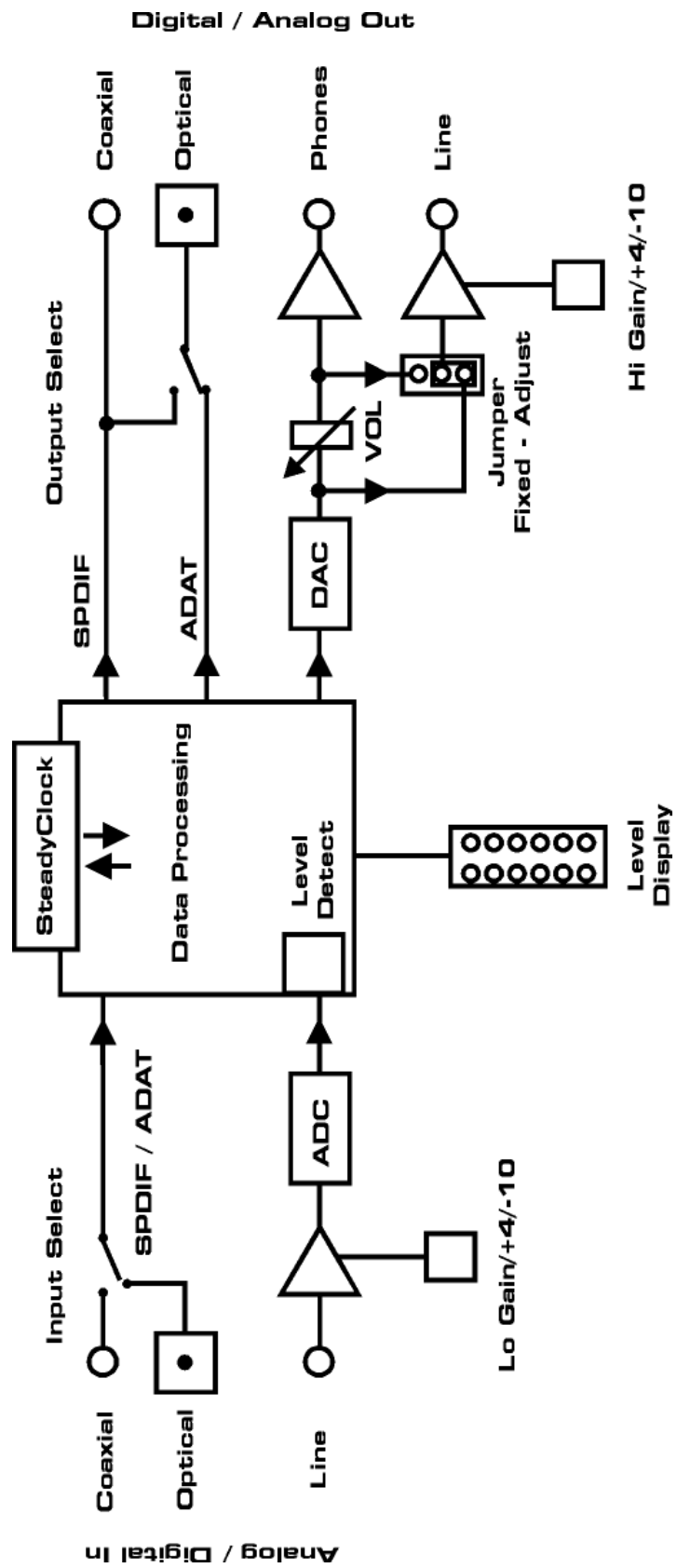

15. Warranty

Each individual ADI-2 undergoes comprehensive quality control and a complete test at IMM before shipping. The usage of high grade components allow us to offer a full two year warranty. We accept a copy of the sales receipt as valid warranty legitimation.

If you suspect that your product is faulty, please contact your local retailer. The warranty does not cover damage caused by improper installation or maltreatment - replacement or repair in such cases can only be carried out at the owner's expense.

RME does not accept claims for damages of any kind, especially consequential damage. Liability is limited to the value of the ADI-2. The general terms of business drawn up by Audio AG apply at all times.

16. Appendix

RME news and further information on our products can be found on our website:

<http://www.rme-audio.com>

Manufacturer:

IMM Elektronik GmbH, Leipziger Str. 32, D-09648 Mittweida

Trademarks

All trademarks and registered trademarks belong to their respective owners. RME, SyncAlign, Hammerfall and SyncCheck are registered trademarks of RME Intelligent Audio Solutions. Intelligent Clock Control, ADI-2 and SteadyClock are trademarks of RME Intelligent Audio Solutions. Alesis and ADAT are registered trademarks of Alesis Corp. ADAT optical is a trademark of Alesis Corp. WaveLab is a trademark of Steinberg Media Technologies GmbH.

Copyright © Matthias Carstens, 08/2010. Version 1.3

All entries in this User's Guide have been thoroughly checked, however no guarantee for correctness can be given. RME cannot be held responsible for any misleading or incorrect information provided throughout this manual. Lending or copying any part or the complete manual or its contents as well as the software belonging to it is only possible with the written permission from RME. RME reserves the right to change specifications at any time without notice.

CE / FCC Compliance

CE

This device has been tested and found to comply with the limits of the European Council Directive on the approximation of the laws of the member states relating to electromagnetic compatibility according to RL2004/108/EG, and European Low Voltage Directive RL2006/95/EG.

FCC

This equipment has been tested and found to comply with the limits for a Class B digital device, pursuant to Part 15 of the FCC Rules. These limits are designed to provide reasonable protection against harmful interference in a residential installation. This equipment generates, uses, and can radiate radio frequency energy and, if not installed and used in accordance with the instructions, may cause harmful interference to radio communications. However, there is no guarantee that interference will not occur in a particular installation. If this equipment does cause harmful interference to radio or television reception, which can be determined by turning the equipment off and on, the user is encouraged to try to correct the interference by one or more of the following measures:

- Reorient or relocate the receiving antenna.
- Increase the separation between the equipment and receiver.
- Connect the equipment into an outlet on a circuit different from that to which the receiver is connected.
- Consult the dealer or an experienced radio/TV technician for help.

RoHS

This product has been soldered lead-free and fulfils the requirements of the RoHS directive.

ISO 9001

This product has been manufactured under ISO 9001 quality management. The manufacturer, IMM Elektronik GmbH, is also certified for ISO 14001 (Environment) and ISO 13485 (medical devices).

Note on Disposal

According to the guide line RL2002/96/EG (WEEE – Directive on Waste Electrical and Electronic Equipment), valid for all european countries, this product has to be recycled at the end of its lifetime.

In case a disposal of electronic waste is not possible, the recycling can also be done by IMM Elektronik GmbH, the manufacturer of the ADI-2.

For this the device has to be sent **free to the door** to:

IMM Elektronik GmbH
Leipziger Straße 32
D-09648 Mittweida
Germany



Shipments not prepaid will be rejected and returned on the original sender's costs.